

15 THUNDERSTORM HAZARDS

Contents

15.1. Precipitation and Hail	545
15.1.1. Heavy Rain	545
15.1.2. Hail	548
15.2. Gust Fronts and Downbursts	554
15.2.1. Attributes	554
15.2.2. Precipitation Drag on the Air	555
15.2.3. Cooling due to Droplet Evaporation	556
15.2.4. Downdraft CAPE (DCAPE)	557
15.2.5. Pressure Perturbation	559
15.2.6. Outflow Winds & Gust Fronts	560
15.3. Lightning and Thunder	563
15.3.1. Origin of Electric Charge	564
15.3.2. Lightning Behavior & Appearance	566
15.3.3. Lightning Detection	568
15.3.4. Lightning Forecasting	569
15.3.5. Lightning Hazards and Safety	569
15.3.6. Thunder	571
15.4. Tornadoes	577
15.4.1. Tangential Velocity & Tornado Intensity	577
15.4.2. Appearance	581
15.4.3. Types of Tornadoes & Other Vortices	582
15.4.4. Evolution as Observed by Eye	583
15.4.5. Tornado Outbreaks	583
15.4.6. Storm-relative Winds	584
15.4.7. Origin of Tornadic Rotation	585
15.4.8. Helicity	587
15.4.9. Multiple-vortex Tornadoes	592
15.5. Review	594
15.6. Homework Exercises	594
15.6.1. Broaden Knowledge & Comprehension	594
15.6.2. Apply	595
15.6.3. Evaluate & Analyze	598
15.6.4. Synthesize	602

The basics of thunderstorms were covered in the previous chapter. Here we cover thunderstorm hazards:

- hail and heavy rain,
- downbursts and gust fronts,
- lightning and thunder,
- tornadoes and mesocyclones.

Two other hazards were covered in the previous chapter: turbulence and vigorous updrafts.

In spite of their danger, thunderstorms can also produce the large-diameter rain drops that enable beautiful rainbows (Fig. 15.1).

15.1. PRECIPITATION AND HAIL

15.1.1. Heavy Rain

Thunderstorms are deep clouds that can create:

- **large raindrops** (2 - 8 mm diameter), in
- **scattered showers** (order of 5 to 10 km diameter rain shafts moving across the ground, resulting in brief-duration rain [1 - 20 min] over any point), of
- **heavy rainfall rate** (10 to over 1000 mm h⁻¹ rainfall rates).

The Precipitation Processes chapter lists world-record rainfall rates, some of which were caused by thunderstorms. Compare this to

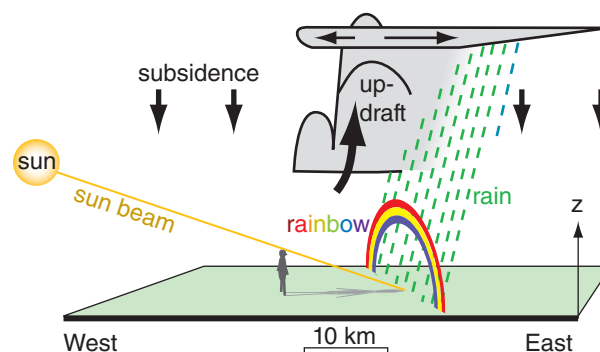

Figure 15.1

Rainbow under an evening thunderstorm. Updraft in the thunderstorm is compensated by weak subsidence around it to conserve air mass, causing somewhat clear skies that allow rays of sunlight to strike the falling large raindrops.



"Practical Meteorology: An Algebra-based Survey of Atmospheric Science" by Roland Stull is licensed under a Creative Commons Attribution-NonCommercial-ShareAlike 4.0 International License. View this license at <http://creativecommons.org/licenses/by-nc-sa/4.0/>. This work is available at https://www.eoas.ubc.ca/books/Practical_Meteorology/

nimbostratus clouds, that create smaller-size **drizzle drops** (0.2 - 0.5 mm) and **small rain drops** (0.5 - 2 mm diameter) in widespread regions (namely, regions hundreds by thousands of kilometers in size, ahead of warm and occluded fronts) of light to moderate rainfall rate that can last for many hours over any point on the ground.

Why do thunderstorms have large-size drops? Thunderstorms are so tall that their tops are in very cold air in the upper troposphere, allowing cold-cloud microphysics even in mid summer. Once a spectrum of different hydrometeor sizes exists, the heavier ice particles fall faster than the smaller ones and collide with them. If the heavier ice particles are falling through regions of supercooled liquid cloud droplets, they can grow by **riming** (as the liquid water instantly freezes on contact to the outside of ice crystals) to form dense, conical-shaped **snow pellets** called **graupel** (< 5 mm diameter). Alternately, if smaller ice crystals fall below the 0°C level, their outer surface partially melts, causing them to stick to other partially-melted ice crystals and grow into miniature fluffy snowballs by a process called **aggregation** to sizes as large as 1 cm in diameter.

The snow aggregates and graupel can reach the ground still frozen or partially frozen, even in summer. This occurs if they are protected within the cool, saturated downdraft of air descending from thunderstorms (downdrafts will be discussed later). At other times, these large ice particles falling through the warmer boundary layer will melt completely into large raindrops just before reaching the ground. These rain drops can make a big splat on your car windshield or in puddles on the ground.

Why do thunderstorms have scattered showers? Often large-size, cloud-free, rain-free subsidence regions form around and adjacent to thunderstorms due to air-mass continuity. Namely, more air mass is pumped into the upper troposphere by thunderstorm updrafts than can be removed by in-storm precipitation-laden downdrafts. Much of the remaining excess air descends more gently outside the storm. This subsidence (Fig. 15.1) tends to suppress other incipient thunderstorms, resulting in cumulonimbus clouds that are either isolated (surrounded by relatively cloud-free air), or are in a thunderstorm line with subsidence ahead and behind the line.

Why do thunderstorms often have heavy rain?

- First, the upper portions of the cumulonimbus cloud are so high that the rising air parcels become so cold (due to the moist-adiabatic cooling rate) that virtually all of the water vapor carried by the air is forced to condense, deposit, or freeze out.

- Second, the vertical stacking of the deep cloud allows precipitation forming in the top of the storm to grow by collision and coalescence or accretion as

it falls through the middle and lower parts of the cloud, as already mentioned, thus sweeping out a lot of water in a short time.

- Third, long-lasting storms such as supercells or orographic storms can have continual inflow of humid boundary-layer air to add moisture as fast as it rains out, thereby allowing the heavy rainfall to persist. As was discussed in the previous chapter, the heaviest precipitation often falls closest to the main updraft in supercells (see Fig. 15.5).

Rainbows are a by-product of having large numbers of large-diameter drops in a localized region surrounded by clear air (Fig. 15.1). Because thunderstorms are more likely to form in late afternoon and early evening when the sun angle is relatively low in the western sky, the sunlight can shine under cloud base and reach the falling raindrops. In North America, where thunderstorms generally move from the southwest toward the northeast, this means that rainbows are generally visible just after the thundershowers have passed, so you can find the rainbow looking toward the east (i.e., look toward your shadow). Rainbow optics are explained in more detail in the last chapter.

Any rain that reached the ground is from water vapor that condensed and did not re-evaporate. Thus, rainfall rate (RR) can be a surrogate measure of the rate of latent heat release:

$$H_{RR} = \rho_L \cdot L_v \cdot RR \quad (15.1)$$

where H_{RR} = rate of energy release in the storm over unit area of the Earth's surface ($J \cdot s^{-1} \cdot m^{-2}$), ρ_L is the density of pure liquid water, L_v is the latent heat of vaporization (assuming for simplicity that all of the precipitation falls out in liquid form), and RR = rainfall rate. Ignoring variations in the values of water density and latent heat of vaporization, this equation reduces to:

$$H_{RR} = a \cdot RR \quad \bullet(15.2)$$

where $a = 694 (J \cdot s^{-1} \cdot m^{-2}) / (mm \cdot h^{-1})$, for rainfall rates in $mm \cdot h^{-1}$.

The corresponding warming rate averaged over the tropospheric depth (assuming the thunderstorm fills the troposphere) was shown in the Heat chapter to be:

$$\Delta T / \Delta t = b \cdot RR \quad (15.3)$$

where $b = 0.33 K (mm \text{ of rain})^{-1}$.

From the Water Vapor chapter recall that **precipitable water**, d_{wp} is the depth of water in a rain gauge if all of the moisture in a column of air were to precipitate out. As an extension of this concept, suppose that pre-storm boundary-layer air of mixing

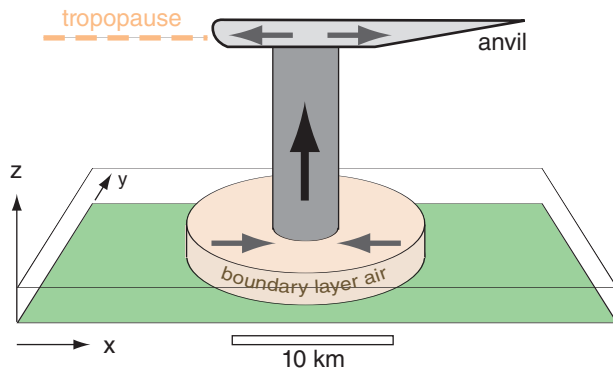

Figure 15.2
The thunderstorm updraft draws in a larger area of warm, humid boundary-layer air, which is fuel for the storm.

ratio 20 g kg^{-1} was drawn up into a column filling the troposphere by the action of convective updrafts (Fig. 15.2). If cloud base was at a pressure altitude of 90 kPa and cloud top was at 30 kPa, and if **half** of the water in the cloudy domain were to condense and precipitate out, then eq. (4.33) says that the depth of water in a rain gauge is expected to be $d_w = 61 \text{ mm}$.

The ratio of amount of rain falling out of a thunderstorm to the inflow of water vapor is called **precipitation efficiency**, and ranges from 5 to 25% for storms in an environment with strong wind shear to 80 to 100% in weakly-sheared environments. The average efficiency of thunderstorms is roughly 50%. Processes that account for the non-precipitating water include anvil outflow of ice crystals that evaporate, evaporation of hydrometeors with entrained air from outside the storm, and evaporation of some of the precipitation before reaching the ground (i.e., **virga**).

Extreme precipitation producing rainfall rates over 100 mm h^{-1} are unofficially called **cloudbursts**. A few cloudbursts or **rain gushes** have been observed with rainfall rates of 1000 mm h^{-1} , but they usually last for only a few minutes. The greater-intensity rainfall events occur less frequently, and have **return periods** (average time between occurrence) of order hundreds of years (see the Rainfall Rates subsection in the Precipitation chapter).

For example, a stationary **orographic thunderstorm** over the eastern Rocky Mountains in Colorado produced an average rainfall rate of 76 mm h^{-1} for 4 hours during 31 July 1976 over an area of about $11 \times 11 \text{ km}$. A total of about 305 mm of rain fell into the catchment of the Big Thompson River, producing a flash flood that killed 139 people in the **Big Thompson Canyon**. This amount of rain is equivalent to a tropospheric warming rate of 25°C h^{-1} , causing a total latent heat release of about $9.1 \times 10^{16} \text{ J}$. This **thunderstorm energy** (based only on latent

Sample Application

A thunderstorm near Holt, Missouri, dropped 305 mm of rain during 0.7 hour. How much net latent heat energy was released into the atmosphere over each square meter of Earth's surface, and how much did it warm the air in the troposphere?

Find the Answer

Given: $RR = 305 \text{ mm} / 0.7 \text{ h} = 436 \text{ mm h}^{-1}$.

Duration $\Delta t = 0.7 \text{ h}$.

Find: $H_{RR} \cdot \Delta t = ? (\text{J} \cdot \text{m}^{-2})$; $\Delta T = ? (^\circ\text{C})$

First, multiply H_{RR} in eq. (15.2) by Δt :

$$H_{RR} \cdot \Delta t = [694 (\text{J} \cdot \text{s}^{-1} \cdot \text{m}^{-2}) / (\text{mm} \cdot \text{h}^{-1})] \cdot [436 \text{ mm h}^{-1}] \cdot [0.7 \text{ h}] \\ [3600 \text{ s/h}] = \underline{762.5 \text{ MJ} \cdot \text{m}^{-2}}$$

Next, use eq. (15.3):

$$\Delta T = b \cdot RR \cdot \Delta t = (0.33 \text{ K mm}^{-1}) \cdot (305 \text{ mm}) \\ = \underline{101^\circ\text{C}}$$

Check: Units OK, but values seem too large???

Exposition: After the thunderstorm has finished raining itself out and dissipating, why don't we observe air that is 101°C warmer where the storm used to be? One reason is that in order to get 305 mm of rain out of the storm, there had to be a continual inflow of humid air bringing in moisture. This same air then carries away the heat as the air is exhausted out of the anvil of the storm.

Thus, the warming is spread over a much larger volume of air than just the air column containing the thunderstorm. Using the factor of 5 as estimated by the needed moisture supply, we get a much more reasonable estimate of $(101^\circ\text{C})/5 \approx 20^\circ\text{C}$ of warming. This is still a bit too large, because we have neglected the mixing of the updraft air with additional environmental air as part of the cloud dynamics, and have neglected heat losses by radiation to space. Also, the Holt storm, like the Big Thompson Canyon storm, was an extreme event — many thunderstorms are smaller or shorter lived.

The net result of the latent heating is that the upper troposphere (anvil level) has warmed because of the storm, while the lower troposphere has cooled as a result of the rain-induced cold-air downburst. Namely, the thunderstorm did its job of removing static instability from the atmosphere, and leaving the atmosphere in a more stable state. This is a third reason why the first thunderstorms reduce the likelihood of subsequent storms.

In summary, the **three reasons why a thunderstorm suppresses neighboring storms** are: (1) the surrounding environment becomes stabilized (smaller CAPE, larger CIN), (2) sources of nearby boundary-layer fuel are exhausted, and (3) subsidence around the storm suppresses other incipient storm updrafts. But don't forget about other thunderstorm processes such as gust fronts that tend to trigger new storms. Thus, competing processes work in thunderstorms, making them difficult to forecast.



© Gene Moore / chaseday.com

Figure 15.3

Large hailstones and damage to car windshield.

heat release) was equivalent to the energy from 23 one-megaton nuclear bomb explosions (given about 4×10^{15} J of heat per **one-megaton nuclear bomb**).

This amount of rain was possible for two reasons: (1) the continual inflow of humid air from the boundary layer into a well-organized (long lasting) orographic thunderstorm (Fig 14.11), and (2) the weakly sheared environment allowed a precipitation efficiency of about 85%. Comparing 305 mm observed with 61 mm expected from a single troposphere-tall column of humid air, we conclude that the equivalent of about 5 troposphere-thick columns of thunderstorm air were consumed by the storm.

Since the thunderstorm is about 6 times as tall as the boundary layer is thick (in pressure coordinates, Fig. 15.2), conservation of air mass suggests that the Big Thompson Canyon storm drew boundary-layer air from an area about $5 \cdot 6 = 30$ times the cross-sectional area of the storm updraft (or 12 times the updraft radius). Namely, a thunderstorm updraft core of 5 km radius would ingest the fuel supply of boundary-layer air from within a radius of 60 km. This is another reason why subsequent storms are less likely in the neighborhood of the first thunderstorm. Namely, the “fuel tank” is empty after the first thunderstorm, until the fuel supply can be re-generated locally via solar heating and evaporation of surface water, or until fresh fuel of warm humid air is blown in by the wind. (See the Sample Application on the previous page for other reasons why a first thunderstorm can suppress later ones.)

15.1.2. Hail

Hailstones are irregularly shaped balls of ice larger than 0.5 cm diameter that fall from severe thunderstorms. The event or process of hailstones falling out of the sky is called **hail**. The damage path on the ground due to a moving hail storm is called a **hail swath**.

Most hailstones are in the 0.5 to 1.5 cm diameter range, with about 25% of the stones greater than 1.5 cm. Hailstones are called **giant hail** (or **large** or **severe hail**) if their diameters are between 1.9 and 5 cm. Hailstones with diameters ≥ 5 cm are called **significant hail** or **enormous hail** (Fig. 15.3). Giant and enormous hail are rare. One stone of diameter 17.8 cm was found in Nebraska, USA, in June 2003. The largest recorded hailstone had diameter 20.3 cm and weighed 878.8 g — it fell in Vivian, South Dakota, USA, on 23 July 2010.

Hailstone diameters are sometimes compared to standard size balls (ping-pong ball = 4 cm; tennis ball \approx 6.5 cm). They are also compared to nonstandard sizes of fruit, nuts, and vegetables. One such classification is the TORRO Hailstone Diameter relationship (Table 15-1).

Table 15-1. TORRO Hailstone Size Classification.

Size Code	Max. Diameter (cm)	Description
0	0.5 - 0.9	Pea
1	1.0 - 1.5	Mothball
2	1.6 - 2.0	Marble, grape
3	2.1 - 3.0	Walnut
4	3.1 - 4.0	Pigeon egg to golf ball
5	4.1 - 5.0	Pullet egg
6	5.1 - 6.0	Hen egg
7	6.1 - 7.5	Tennis ball to cricket ball
8	7.6 - 9.0	Large orange to soft ball
9	9.1 - 10.0	Grapefruit
10	> 10.0	Melon

15.1.2.1. Hail Damage

Large diameter hailstones can cause severe damage to crops, tree foliage, cars, aircraft, and sometimes buildings (roofs and windows). Damage is often greater if strong winds cause the hailstones to move horizontally as they fall. Most humans are smart enough not to be outside during a hail storm, so deaths due to hail in North America are rare, but animals can be killed. Indoors is the safest place for people in a hail storm, although inside a metal-roofed vehicle is also relatively safe. Stay away from windows, which can break.

The terminal fall velocity of hail increases with hailstone size, and can reach magnitudes greater than 50 m s⁻¹ for large hailstones. An equation for hailstone terminal velocity was given in the Precipitation chapter, and a graph of it is shown here in Fig. 15.4. Hailstones have different shapes (smooth and round vs. irregular shaped with protuberances) and densities (average ρ_{ice} is 900 kg m⁻³, but this varies depending on the amount of air bubbles). This causes a range of air drags (0.4 to 0.8, with average 0.55) and a corresponding range of terminal fall speeds. Hailstones that form in the updraft vault region of a supercell thunderstorm are so heavy that most fall immediately adjacent to the vault (Fig. 15.5).

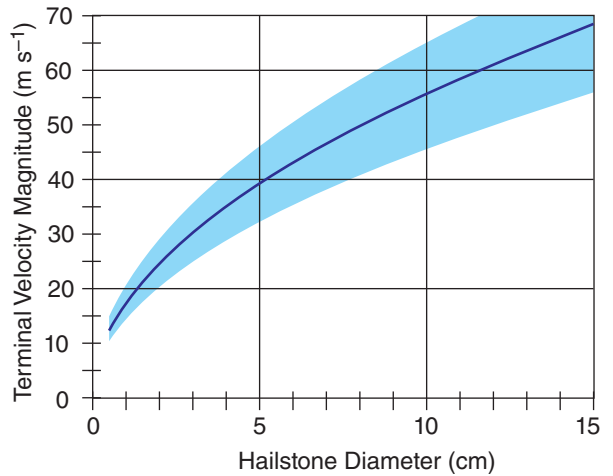

Figure 15.4
Hailstone fall-velocity magnitude relative to the air at pressure height of 50 kPa, assuming an air density of 0.69 kg m⁻³.

15.1.2.2. Hail Formation

Two stages of hail development are embryo formation, and then hailstone growth. A hail **embryo** is a large frozen raindrop or graupel particle (< 5 mm diameter) that is heavy enough to fall at a different speed than the surrounding smaller cloud droplets. It serves as the nucleus of hailstones. Like all normal (non-hail) precipitation, the embryo first rises in the updraft as a growing cloud droplet or ice crystal that eventually becomes large enough (via collision and accretion, as discussed in the Precipitation chapter) to begin falling back toward Earth.

While an embryo is being formed, it is still so small that it is easily carried up into the anvil and out of the thunderstorm, given typical severe thunderstorm updrafts of 10 to 50 m s⁻¹. Most potential embryos are removed from the thunderstorm this way, and thus cannot then grow into hailstones.

The few embryos that do initiate hail growth are formed in regions where they are not ejected from the storm, such as: (1) outside of the main updraft in the flanking line of cumulus congestus clouds or in other smaller updrafts, called **feeder cells**; (2) in a side eddy of the main updraft; (3) in a portion of the main updraft that tilts upshear; or (4) earlier in the evolution of the thunderstorm while the main updraft is still weak. Regardless of how they are formed, it is believed that the embryos then move or fall into the main updraft of the severe thunderstorm a second time.

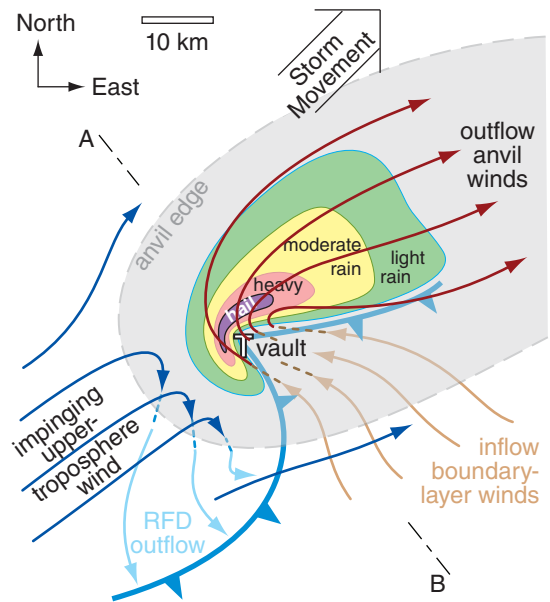

Figure 15.5
Plan view of classic (CL) supercell in the N. Hemisphere (copied from the Thunderstorm chapter). Low altitude winds are shown with light-colored arrows, high altitude with darker arrows, and ascending/descending air with dashed lines. T indicates tornado location. Precipitation is at the ground. Cross section A-B is used in Fig. 15.10.

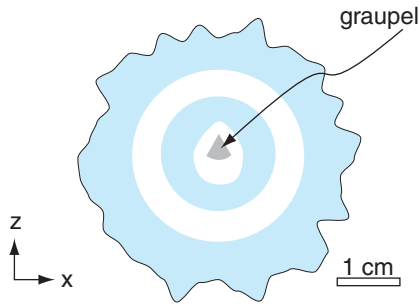

Figure 15.6

Illustration of slice through a hailstone, showing a graupel embryo surrounded by 4 layers of alternating clear ice (indicated with blue shading) and porous (white) ice.

Sample Application

If a supercooled cloud droplet of radius $50\ \mu\text{m}$ and temperature -20°C hits a hailstone, will it freeze instantly? If not, how much heat must be conducted out of the droplet (to the hailstone and the air) for the droplet to freeze?

Find the Answer

Given: $r = 50\ \mu\text{m} = 5 \times 10^{-5}\ \text{m}$, $T = -20^\circ\text{C}$

Find: $\Delta Q_E = ?\ \text{J}$, $\Delta Q_H = ?\ \text{J}$,

Is $\Delta Q_E < \Delta Q_H$? If no, then find $\Delta Q_E - \Delta Q_H$.

Use latent heat and specific heat for liquid water, from Appendix B.

Assume a spherical droplet of mass

$$m_{liq} = \rho_{liq} \cdot Vol = \rho_{liq} \cdot (4/3) \cdot \pi \cdot r^3 \\ = (1000\ \text{kg m}^{-3}) \cdot (4/3) \cdot \pi \cdot (5 \times 10^{-5}\ \text{m})^3 = 5.2 \times 10^{-10}\ \text{kg}$$

Use eq. (3.3) to determine how much heat must be removed to freeze the whole droplet ($\Delta m = m_{liq}$):

$$\Delta Q_E = L_f \cdot \Delta m = (3.34 \times 10^5\ \text{J kg}^{-1}) \cdot (5.2 \times 10^{-10}\ \text{kg}) \\ = 1.75 \times 10^{-4}\ \text{J}.$$

Use eq. (3.1) to find how much can be taken up by allowing the droplet to warm from -20°C to 0°C :

$$\Delta Q_H = m_{liq} \cdot c_{liq} \cdot \Delta T \\ = (5.2 \times 10^{-10}\ \text{kg}) \cdot [4217.6\ \text{J (kg}\cdot\text{K)}^{-1}] \cdot [0^\circ\text{C} - (-20^\circ\text{C})] \\ = 0.44 \times 10^{-4}\ \text{J}.$$

Thus $\Delta Q_E > \Delta Q_H$, so the sensible-heat deficit associated with -20°C is not enough to compensate for the latent heat of fusion needed to freeze the drop. The droplet will **NOT** freeze instantly.

The amount of heat remaining to be conducted away to the air or the hailstone to allow freezing is:

$$\Delta Q = \Delta Q_E - \Delta Q_H = (1.75 \times 10^{-4}\ \text{J}) - (0.44 \times 10^{-4}\ \text{J}) \\ = \mathbf{1.31 \times 10^{-4}\ \text{J}}.$$

Check: Units OK. Physics OK.

Exposition: During the several minutes needed to conduct away this heat, the liquid can flow over the hailstone before freezing, and some air can escape. This creates a layer of clear ice.

The hailstone grows during this second trip through the updraft. Even though the embryo is initially rising in the updraft, the smaller surrounding supercooled cloud droplets are rising faster (because their terminal fall velocity is slower), and collide with the embryo. Because of this requirement for abundant supercooled cloud droplets, hail forms at altitudes where the air temperature is between -10 and -30°C . Most growth occurs while the hailstones are floating in the updraft while drifting horizontally across the updraft in a narrow altitude range having temperatures of -15 to -20°C .

In pockets of the updraft happening to have relatively low liquid water content, the supercooled cloud droplets can freeze almost instantly when they hit the hailstone, trapping air in the interstices between the frozen droplets. This results in a porous, brittle, white layer around the hailstone. In other portions of the updraft having greater liquid water content, the water flows around the hail and freezes more slowly, resulting in a hard clear layer of ice. The result is a hailstone with 2 to 4 visible layers around the embryo (when the hailstone is sliced in half, as sketched in Fig. 15.6), although most hailstones are small and have only one layer. Giant hail can have more than 4 layers.

As the hailstone grows and becomes heavier, its terminal velocity increases and eventually surpasses the updraft velocity in the thunderstorm. At this point, it begins falling relative to the ground, still growing on the way down through the supercooled cloud droplets. After it falls into the warmer air at low altitude, it begins to melt. Almost all strong thunderstorms have some small hailstones, but most melt into large rain drops before reaching the ground. Only the larger hailstones (with more frozen mass and quicker descent through the warm air) reach the ground still frozen as hail (with diameters $> 5\ \text{mm}$).

15.1.2.3. Hail Forecasting

Forecasting large-hail potential later in the day is directly tied to forecasting the maximum updraft velocity in thunderstorms, because only in the stronger updrafts can the heavier hailstones be kept aloft against their terminal fall velocities (Fig. 15.4). CAPE is an important parameter in forecasting updraft strength, as was given in eqs. (14.7) and (14.8) of the Thunderstorm chapter. Furthermore, since it takes about 40 to 60 minutes to create hail (including both embryo and hail formation), large hail would be possible only from long-lived thunderstorms, such as supercells that have relatively steady organized updrafts (which can exist only in an environment with appropriate wind shear).

However, even if all these conditions are satisfied, hail is not guaranteed. So national forecast

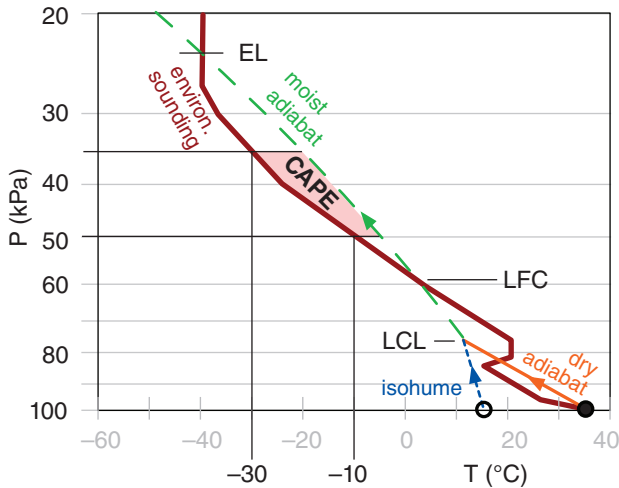

Figure 15.7
 Shaded pink is the portion of CAPE area between altitudes where the environment is between -10 and -30°C . Greater areas indicate greater hail likelihood.

centers in North America do not issue specific hail watches, but include hail as a possibility in severe thunderstorm watches and warnings.

To aid in hail forecasting, meteorologists sometimes look at forecast maps of the portion of CAPE between altitudes where the environmental air temperature is $-30 \leq T \leq -10^{\circ}\text{C}$, such as sketched in Fig. 15.7. Larger values (on the order of 400 J kg^{-1} or greater) of this portion of CAPE are associated with more rapid hail growth. Computers can easily calculate this portion of CAPE from soundings produced by numerical forecast models, such as for the case shown in Fig. 15.8. Within the shaded region of large CAPE on this figure, hail would be forecast at only those subsets of locations where thunderstorms actually form.

Weather maps of freezing-level altitude and wind shear between 0 to 6 km are also used by hail forecasters. More of the hail will reach the ground without melting if the freezing level is at a lower altitude. Environmental wind shear enables longer-duration supercell updrafts, which favor hail growth.

Research is being done to try to create a single forecast parameter that combines many of the factors favorable for hail. One example is the **Significant Hail Parameter (SHIP)**:

$$\text{SHIP} = \{ \text{MUCAPE}(\text{J kg}^{-1}) \cdot r_{\text{MUP}}(\text{g kg}^{-1}) \cdot \gamma_{70-50\text{kPa}}(^{\circ}\text{C km}^{-1}) \cdot [-T_{50\text{kPa}}(^{\circ}\text{C})] \cdot \text{TSM}_{0-6\text{km}}(\text{m s}^{-1}) \} / a \quad (15.4)$$

where r_{MUP} is the water vapor mixing ratio for the most-unstable air parcel, $\gamma_{70-50\text{kPa}}$ is the average en-

Sample Application

What is the largest size hailstone that could be supported in a thunderstorm having $\text{CAPE} = 1976 \text{ J kg}^{-1}$? Also give its TORRO classification.

Find the Answer

Given: $\text{CAPE} = 1976 \text{ J kg}^{-1}$.
 Find: $d_{\text{max}} = ? \text{ cm}$ (max hailstone diameter)

From Appendix A, note that units $\text{J kg}^{-1} = \text{m}^2 \text{ s}^{-2}$. First, use eqs. (14.7) and (14.8) from the Thunderstorm chapter to get the likely max updraft speed. This was already computed in a Sample Application near those eqs:

$$w_{\text{max likely}} = 31 \text{ m s}^{-1}$$

Assume that the terminal fall velocity of the largest hailstone is just balanced by this updraft.

$$w_T = -w_{\text{max likely}} = -31 \text{ m s}^{-1}$$

where the negative sign implies downward motion. Then use Fig. 15.4 to find the diameter.

$$d_{\text{max}} \approx \mathbf{3.1 \text{ cm}}$$

From Table 15-1, the TORRO hail **size code is 4**, which corresponds to **pigeon egg to golf ball size**.

Check: Units OK. Physics OK.

Exposition: Hail this size would be classified as large or giant hail, and could severely damage crops.

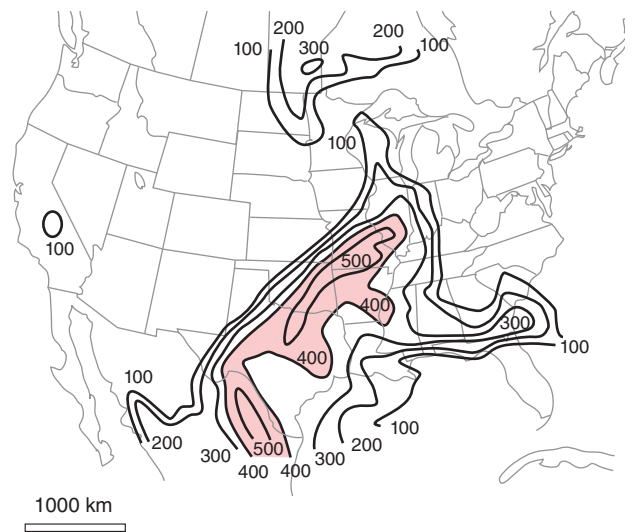

Figure 15.8
 Portion of CAPE (J kg^{-1}) between altitudes where the environment is between -10 and -30°C . Larger values indicate chance of greater hail growth rates. Case: 22 UTC on 24 May 2006 over the USA and Canada.

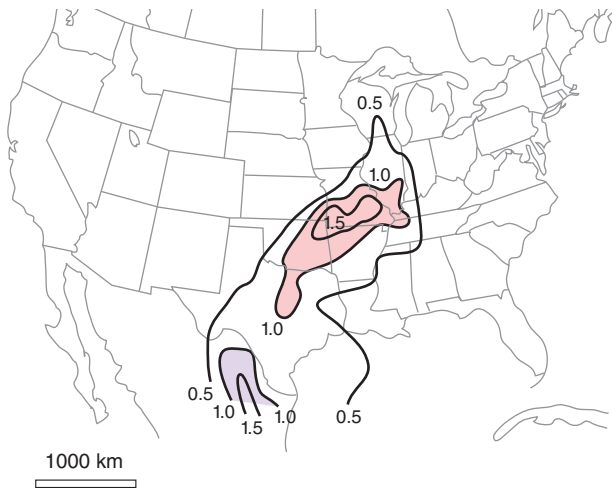

Figure 15.9
Values of significant hail parameter (*SHIP*) over the USA for the same case as the previous figure. This parameter is dimensionless.

Sample Application

Suppose a pre-storm environmental sounding has the following characteristics over a corn field:

$$\begin{aligned} MUCAPE &= 3000 \text{ J kg}^{-1}, \\ r_{MUP} &= 14 \text{ g kg}^{-1}, \\ \gamma_{70-50kPa} &= 5 \text{ }^\circ\text{C km}^{-1}, \\ T_{50kPa} &= -10^\circ\text{C} \\ TSM_{0-6km} &= 45 \text{ m s}^{-1} \end{aligned}$$

If a thunderstorm forms in this environment, would significant hail (with diameters ≥ 5 cm) be likely?

Find the Answer

Given: values listed above

Find: $SHIP = ?$.

Use eq. (15.4):

$$\begin{aligned} SHIP &= [(3000 \text{ J kg}^{-1}) \cdot (14 \text{ g kg}^{-1}) \cdot (5 \text{ }^\circ\text{C km}^{-1}) \cdot \\ &\quad (10^\circ\text{C}) \cdot (45 \text{ m s}^{-1})] / (44 \times 10^6) \\ &= 99.5 \times 10^6 / (44 \times 10^6) = \mathbf{2.15} \end{aligned}$$

Check: Units are dimensionless. Value reasonable.

Exposition: Because *SHIP* is much greater than 1.0, significant (tennis ball size or larger) hail is indeed likely. This would likely totally destroy the corn crop. Because hail forecasting has so many uncertainties and often short lead times, the farmers don't have time to take action to protect or harvest their crops. Thus, their only recourse is to purchase crop insurance.

environmental lapse rate between pressure heights 70 and 50 kPa, T_{50kPa} is the temperature at a pressure height of 50 kPa, TSM_{0-6km} is the total shear magnitude between the surface and 6 km altitude, and empirical parameter $a = 44 \times 10^6$ (with dimensions equal to those shown in the numerator of the equation above, so as to leave *SHIP* dimensionless).

This parameter typically ranges from 0 to 4 or so. If $SHIP > 1$, then the prestorm environment is favorable for significant hail (i.e., hail diameters ≥ 5 cm). Significant hail is frequently observed when $SHIP \geq 1.5$. Fig. 15.9 shows a weather map of *SHIP* for the 22 UTC 24 May 2006 case study.

Nowcasting (forecasting 1 to 30 minutes ahead) large hail is aided with weather radar:

- Large hailstones cause very large radar reflectivity (order of 60 to 70 dBZ) compared to the maximum possible from very heavy rain (up to 50 dBZ). Some radar algorithms diagnose hail when it finds reflectivities ≥ 40 dBZ at altitudes where temperatures are below freezing, with greater chance of hail for ≥ 50 dBZ at altitudes above the -20°C level.
- Doppler velocities can show if a storm is organized as a supercell, which is statistically more likely to support hail.
- Polarimetric methods (see the Satellites & Radar chapter) allow radar echoes from hail to be distinguished from echoes from rain or smaller ice particles.
- The updrafts in some supercell thunderstorms are so strong that only small cloud droplets exist, causing weak (< 25 dBZ) radar reflectivity, and resulting in a **weak-echo region (WER)** on the radar display. Sometimes the WER is surrounded on the top and sides by strong precipitation echoes, causing a **bounded weak-echo region (BWER)**, also known as an **echo-free vault**. This enables very large hail, because embryos falling from the upshear side of the bounding precipitation can re-enter the updraft, thereby efficiently creating hail (Fig. 15.10).

15.1.2.4. Hail Locations

The hail that does fall often falls closest to the main updraft (Figs. 15.5 & 15.10), and the resulting **hail shaft** (the column of falling hailstones below cloud base) often looks white or invisible to observers on the ground. Most hail falls are relatively short lived, causing small (10 to 20 km long, 0.5 to 3 km wide) damage tracks called **hailstreaks**. Sometimes long-lived supercell thunderstorms can create longer **hailswaths** of damage 8 to 24 km wide and 160 to 320 km long. Even though large hail can be extremely damaging, the mass of water in hail at the

ground is typically only 2 to 3% of the mass of rain from the same thunderstorm.

In the USA, most giant hail reaching the ground is found in the central and southern plains, centered in Oklahoma (averaging 6 to 9 giant-hail days yr^{-1}), and extending from Texas north through Kansas and Nebraska (3 or more giant-hail days yr^{-1}). Hail is also observed less frequently (1 to 3 giant-hail days yr^{-1}) eastward across the Mississippi valley and into the southern and mid-Atlantic states.

Although hail is less frequent in Canada than in the USA, significant hail falls are found in Alberta between the cities of Calgary and Edmonton, particularly near the town of Red Deer. Hail is also found in central British Columbia, and in the southern prairies of Saskatchewan and Manitoba.

In the S. Hemisphere, hail falls often occur over eastern Australia. The 14 April 1999 hailstorm over Sydney caused an estimated AUS\$ 2.2 billion in damage, the second largest weather-related damage total on record for Australia. Hailstorms have been observed over North and South America, Europe, Australia, Asia, and Africa.

15.1.2.5. Hail Mitigation

Attempts at **hail suppression** (mitigation) have generally been unsuccessful, but active hail-suppression efforts still continue in most continents to try to reduce crop damage. Five approaches have been suggested for suppressing hail, all of which involve **cloud seeding** (adding particles into clouds to serve as additional or specialized hydrometeor nuclei), which is difficult to do with precision:

- **beneficial competition** - to create larger numbers of embryos that compete for supercooled cloud water, thereby producing larger numbers of smaller hailstones (that melt before reaching the ground). The methods are cloud seeding with **hygroscopic** (attracts water; e.g., salt particles) cloud nuclei (to make larger rain drops that then freeze into embryos), or seeding with **glaciogenic** (makes ice; e.g., silver iodide particles) ice nuclei to make more graupel.
- **early rainout** - to cause precipitation in the cumulus congestus clouds of the flanking line, thereby reducing the amount of cloud water available before the updraft becomes strong enough to support large hail. The method is seeding with ice nuclei.
- **trajectory altering** - to cause the embryos to grow to greater size earlier, thereby following a lower trajectory through the updraft where the temperature or supercooled liquid water content is not optimum for large hail growth. This method attempts to increase rainfall (in drought regions) while reducing hail falls.

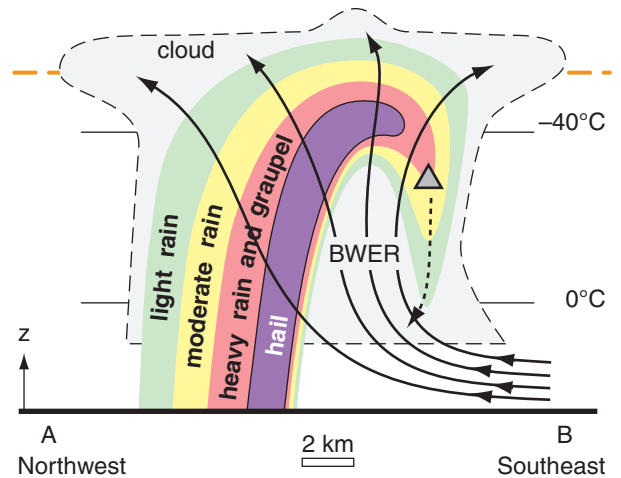

Figure 15.10

Vertical cross section through a classic supercell thunderstorm along slice A-B from Fig. 15.5. Thin dashed line shows visible cloud boundary, and colors mimic the intensity of precipitation as viewed by radar. BWER = bounded weak echo region of supercooled cloud droplets. Grey triangle represents graupel on the upshear side of the storm, which can fall (dotted line) and re-enter the updraft to serve as a hail embryo. Thick dashed orange line is the tropopause. Isotherms are thin solid horizontal black lines. Curved thick black lines with arrows show air flow.

INFO • Hail Suppression

For many years there has been a very active cloud seeding effort near the town of Red Deer, Alberta, Canada, in the hopes of suppressing hail. These activities were funded by some of the crop-insurance companies, because their clients, the farmers, demanded that something be done.

Although the insurance companies knew that there is little solid evidence that hail suppression actually works, they funded the cloud seeding anyway as a public-relations effort. The farmers appreciated the efforts aimed at reducing their losses, and the insurance companies didn't mind because the cloud-seeding costs were ultimately borne by the farmers via increased insurance premiums.

Sample Application

During cloud seeding, how many silver iodide particles need to be introduced into a thunderstorm to double the number of ice nuclei? Assume the number density of natural ice nuclei is 10,000 per cubic meter.

Find the Answer

Given: $n_{ice\ nuclei}/Volume = 10,000\ m^{-3}$
 Find: $N_{total} = ?$ total count of introduced nuclei

To double ice nuclei, the count of introduced nuclei must equal the count of natural nuclei:

$$N_{total} = (n_{ice\ nuclei}/Volume) \cdot Volume$$

Estimate the volume of a thunderstorm above the freezing level. Assume freezing level is at 3 km altitude, and the anvil top is at 12 km. Approximate the thunderstorm by a box of bottom surface area 12 x 12 km, and height 9 km (= 12 - 3).

$$Volume \approx 1300\ km^3 = 1.3 \times 10^{12}\ m^3$$

Thus:

$$N_{total} = (n_{ice\ nuclei}/Volume) \cdot Volume = (10,000\ m^{-3}) \cdot (1.3 \times 10^{12}\ m^3) = \mathbf{1.3 \times 10^{16}}$$

Check: Units OK. Physics OK.

Exposition: Cloud seeding is often done by an aircraft. For safety reasons, the aircraft doesn't usually fly into the violent heart of the thunderstorm. Instead, it flies under the rain-free portion of cloud base, releasing the silver iodide particles into the updraft in the hopes that the nuclei get to the right part of the storm at the right time. It is not easy to do this correctly, and even more difficult to confirm if the seeding caused the desired change. Seeding thunderstorms is an uncontrolled experiment, and one never knows how the thunderstorm would have changed without the seeding.

- **dynamic effects** - to consume more CAPE earlier in the life cycle of the updraft (i.e., in the cumulus congestus stage), thereby leaving less energy for the main updraft, causing it to be weaker (and supporting only smaller hail).
- **glaciation of supercooled cloud water** - to more quickly convert the small supercooled cloud droplets into small ice crystals that are less likely to stick to hail embryos and are more likely to be blown to the top of the storm and out via the anvil. This was the goal of most of the early attempts at hail suppression, but has lost favor as most hail suppression attempts have failed.

15.2. GUST FRONTS AND DOWNBURSTS

15.2.1. Attributes

Downbursts are rapidly descending ($w = -5$ to $-25\ m\ s^{-1}$) downdrafts of air (Fig. 15.11), found below clouds with precipitation or virga. Downbursts of 0.5 to 10 km diameter are usually associated with thunderstorms and heavy rain. Downburst speeds of order $10\ m\ s^{-1}$ have been measured 100 m AGL. The descending air can hit the ground and spread out as strong **straight-line winds** causing damage equivalent to a weak tornado (up to EF3 intensity). Smaller mid-level clouds (e.g., altocumulus with virga) can also produce downbursts that usually do not reach the ground.

Small diameter (1 to 4 km) downbursts that last only 2 to 5 min are called **microbursts**. Sometimes a downburst area will include one or more embedded microbursts.

Acceleration of downburst velocity w is found by applying Newton's 2nd law of motion to an air parcel:

$$\frac{\Delta w}{\Delta t} \approx -\frac{1}{\rho} \frac{\Delta P'}{\Delta z} + |g| \left[\frac{\theta'_v}{\theta_{ve}} - \frac{C_v}{C_p} \frac{P'}{P_e} \right] \quad \bullet(15.5)$$

Term: (A) (B) (C)

where w is negative for downdrafts, t is time, ρ is air density, $P' = P_{parcel} - P_e$ is pressure perturbation of the air parcel relative to the environmental pressure P_e , z is height, $|g| = 9.8\ m\ s^{-2}$ is the magnitude of gravitational acceleration, $\theta'_v = \theta_{v\ parcel} - \theta_{ve}$ is the deviation of the parcel's virtual potential temperature from that of the environment θ_{ve} (in Kelvin), and $C_v/C_p = 0.714$ is the ratio of specific heat of air at constant volume to that at constant pressure.

Remember that the virtual potential temperature (from the Heat chapter) includes liquid-water and ice loading, which makes the air act as if it were

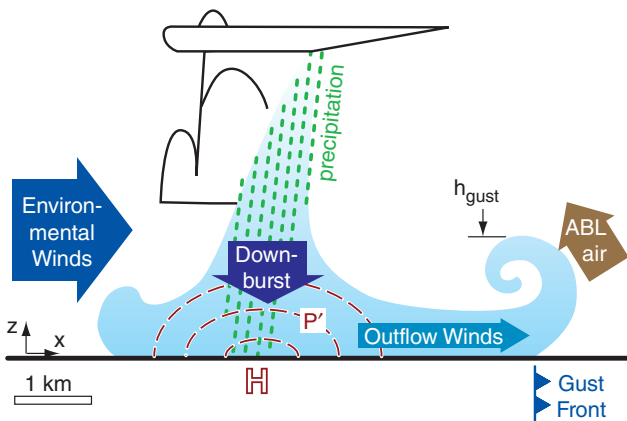

Figure 15.11
 Vertical slice through a thunderstorm downburst and its associated gust front. Light blue area indicates the rain-cooled air. Behind the gust front are non-tornadic (i.e., straight-line) outflow winds. H indicates location of meso-high pressure at the surface, and isobars of positive pressure perturbation P' are dashed red lines. Dotted lines show precipitation. ABL is the warm, humid environmental air in the atmospheric boundary layer.

colder, denser, and heavier. Namely, for the air parcel it is:

$$\theta_{v \text{ parcel}} = \theta_{\text{parcel}} \cdot (1 + 0.61 \cdot r - r_L - r_I)_{\text{parcel}} \quad (15.6)$$

where θ is air potential temperature (in Kelvin), r is water-vapor mixing ratio (in g g^{-1} , not g kg^{-1}), r_L is liquid water mixing ratio (in g g^{-1}), and r_I is ice mixing ratio (in g g^{-1}). For the special case of an environment with no liquid water or ice, the environmental virtual potential temperature is:

$$\theta_{ve} = \theta_e \cdot (1 + 0.61 \cdot r)_e \quad (15.7)$$

Equation (15.5) says that three forces (per unit mass) can create or enhance downdrafts. (A) Pressure-gradient force is caused when there is a difference between the pressure profile in the environment (which is usually hydrostatic) and that of the parcel. (B) Buoyant force combines the effects of temperature in the evaporatively cooled air, precipitation drag associated with falling rain drops or ice crystals, and the relatively lower density of water vapor. (C) Perturbation-pressure buoyancy force is where an air parcel of lower pressure than its surroundings experiences an upward force. Although this last effect is believed to be small, not much is really known about it, so we will neglect it here.

Evaporative cooling and precipitation drag are important for initially accelerating the air downward out of the cloud. We will discuss those factors first, because they can create downbursts. The vertical pressure gradient becomes important only near the ground. It is responsible for decelerating the downburst just before it hits the ground, which we will discuss in the “gust front” subsection.

15.2.2. Precipitation Drag on the Air

When **hydrometeors** (rain drops and ice crystals) fall at their terminal velocity through air, the drag between the hydrometeor and the air tends to pull some of the air with the falling precipitation. This **precipitation drag** produces a downward force on the air equal to the weight of the precipitation particles. For details on precipitation drag, see the Precipitation Processes Chapter.

This effect is also called **liquid-water loading** or **ice loading**, depending on the phase of the hydrometeor. The downward force due to precipitation loading makes the air parcel act heavier, having the same effect as denser, colder air. As was discussed in the Atmos. Basics and Heat Budgets chapters, use virtual temperature T_v or virtual potential temperature θ_v to quantify this effective cooling.

Sample Application

10 g kg^{-1} of liquid water exists as rain drops in saturated air of temperature 10°C and pressure 80 kPa. The environmental air has a temperature of 10°C and mixing ratio of 4 g kg^{-1} . Find the: (a) buoyancy force per mass associated with air temperature and water vapor, (b) buoyancy force per mass associated with just the precipitation drag, and (c) the downdraft velocity after 1 minute of fall, due to only (a) and (b).

Find the Answer

Given: Parcel: $r_L = 10 \text{ g kg}^{-1}$, $T = 10^\circ\text{C}$, $P = 80 \text{ kPa}$,
 Environ.: $r = 4 \text{ g kg}^{-1}$, $T = 10^\circ\text{C}$, $P = 80 \text{ kPa}$,
 $\Delta t = 60 \text{ s}$. Neglect terms (A) and (C).

Find: (a) $\text{Term}(B_{\text{due to } T \text{ \& } r}) = ? \text{ N kg}^{-1}$,
 (b) $\text{Term}(B_{\text{due to } r_L \text{ \& } r_I}) = ? \text{ N kg}^{-1}$ (c) $w = ? \text{ m s}^{-1}$

(a) Because the parcel air is saturated, $r_{\text{parcel}} = r_s$. Using a thermo diagram (because its faster than solving a bunch of equations), $r_s \approx 9.5 \text{ g kg}^{-1}$ at $P = 80 \text{ kPa}$ and $T = 10^\circ\text{C}$. Also, from the thermo diagram, $\theta_{\text{parcel}} \approx 28^\circ\text{C} = 301 \text{ K}$. Thus, using the first part of eq. (15.6):

$$\theta_{v \text{ parcel}} \approx (301 \text{ K}) \cdot [1 + 0.61 \cdot (0.0095 \text{ g g}^{-1})] \approx 302.7 \text{ K}$$

For the environment, also $\theta \approx 28^\circ\text{C} = 301 \text{ K}$, but $r = 4 \text{ g kg}^{-1}$. Thus, using eq. (15.7):

$$\theta_{ve} \approx (301 \text{ K}) \cdot [1 + 0.61 \cdot (0.004 \text{ g g}^{-1})] \approx 301.7 \text{ K}$$

Use eq. (15.5):

$$\begin{aligned} \text{Term}(B_{\text{due to } T \text{ \& } r}) &= |g| \cdot [(\theta_{v \text{ parcel}} - \theta_{ve}) / \theta_{ve}] \\ &= (9.8 \text{ m s}^{-2}) \cdot [(302.7 - 301.7 \text{ K}) / 301.7 \text{ K}] \\ &= 0.032 \text{ m s}^{-2} = \mathbf{0.032 \text{ N kg}^{-1}}. \end{aligned}$$

(b) Because r_I was not given, assume $r_I = 0$ everywhere, and $r_L = 0$ in the environment.

$$\begin{aligned} \text{Term}(B_{\text{due to } r_L \text{ \& } r_I}) &= -|g| \cdot [(r_L + r_I)_{\text{parcel}} - (r_L + r_I)_e] \\ &= -(9.8 \text{ m s}^{-2}) \cdot [0.01 \text{ g g}^{-1}] = \mathbf{-0.098 \text{ N kg}^{-1}}. \end{aligned}$$

(c) Assume initial vertical velocity is zero.

Use eq. (15.5) with only Term B:

$$\begin{aligned} (w_{\text{final}} - w_{\text{initial}}) / \Delta t &= [\text{Term}(B_{T \text{ \& } r}) + \text{Term}(B_{r_L \text{ \& } r_I})] \\ w_{\text{final}} &= (60 \text{ s}) \cdot [0.032 - 0.098 \text{ m s}^{-2}] \approx \mathbf{-4 \text{ m s}^{-1}}. \end{aligned}$$

Check: Units OK. Physics OK.

Exposition: Although the water vapor in the air adds buoyancy equivalent to a temperature increase of 1°C , the liquid-water loading decreases buoyancy, equivalent to a temperature decrease of 3°C . The net effect is that this saturated, liquid-water laden air acts 2°C colder and heavier than dry air at the same T .

CAUTION. The final vertical velocity assumes that the air parcel experiences constant buoyancy forces during its 1 minute of fall. This is NOT a realistic assumption, but it did make the exercise a bit easier to solve. In fact, if the rain-laden air descends below cloud base, then it is likely that the rain drops are in an unsaturated air parcel, not saturated air as was stated for this exercise. We also neglected turbulent drag of the downburst air against the environmental air. This effect can greatly reduce the actual downburst speed compared to the idealized calculations above.

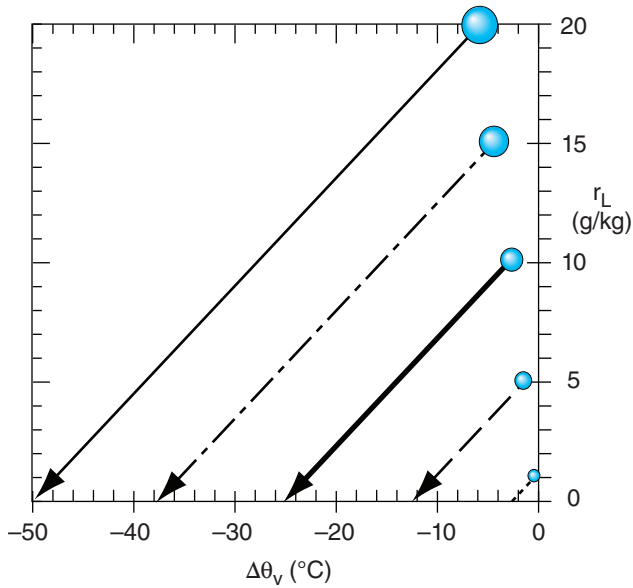

Figure 15.12

Rain drops reduce the virtual potential temperature of the air by both their weight (precipitation drag) and cooling as they evaporate. $\Delta\theta_v$ is the change of virtual potential temperature compared to air containing no rain drops initially. r_L is liquid-water mixing ratio for the drops in air. For any initial r_L along the vertical axis, the blue dot indicates the $\Delta\theta_v$ due to only liquid water loading. As that same raindrop evaporates, follow the diagonal line down to see changes in both r_L and $\Delta\theta_v$.

Sample Application

For data from the previous Sample Application, find the virtual potential temperature of the air if:

- all liquid water evaporates, and
- no liquid water evaporates, leaving only the precipitation-loading effect.
- Discuss the difference between (a) and (b)

Find the Answer

Given: $r_L = 10 \text{ g kg}^{-1}$ initially. $r_L = 0$ finally.

Find: (a) $\Delta\theta_{\text{parcel}} = ? \text{ K}$ (b) $\Delta\theta_{\text{v parcel}} = ? \text{ K}$

(a) Use eq. (15.8):

$$\Delta\theta_{\text{parcel}} = [2.5 \text{ K kg}_{\text{air}} \cdot (\text{g}_{\text{water}})^{-1}] \cdot (-10 \text{ g kg}^{-1}) = \underline{\underline{-25 \text{ K}}}$$

(b) From the Exposition section of the previous Sample Application:

$$\Delta\theta_{\text{v parcel precip. drag}} = -3 \text{ K initially.}$$

Thus, the **change** of virtual potential temperature (between before and after the drop evaporates) is

$$\begin{aligned} \Delta\theta_{\text{v parcel}} &= \Delta\theta_{\text{v parcel final}} - \Delta\theta_{\text{v parcel initial}} \\ &= -25 \text{ K} - (-3 \text{ K}) = \underline{\underline{-22 \text{ K}}}. \end{aligned}$$

Check: Units OK. Physics OK.

Exposition: (c) The rain is more valuable to the downburst if it all evaporates.

15.2.3. Cooling due to Droplet Evaporation

Three factors can cause the rain-filled air to be unsaturated. (1) The rain can fall out of the thunderstorm into drier air (namely, the rain moves through the air parcels, not with the air parcels). (2) As air parcels descend in the downdraft (being dragged downward by the rain), the air parcels warm adiabatically and can hold more vapor. (3) Mixing of the rainy air with the surrounding drier environment can result in a mixture with lowered humidity.

Raindrops can partially or totally evaporate in this unsaturated air, converting sensible heat into latent heat. Namely, air cools as the water evaporates, and cool air has negative buoyancy. Negatively buoyant air sinks, creating downbursts of air. One way to quantify the cooling is via the change of potential temperature associated with evaporation of Δr_L ($\text{g}_{\text{liq. water}} \text{ kg}_{\text{air}}^{-1}$) of liquid water:

$$\Delta\theta_{\text{parcel}} = (L_v/C_p) \cdot \Delta r_L \quad \bullet(15.8)$$

where $(L_v/C_p) = 2.5 \text{ K kg}_{\text{air}} \cdot (\text{g}_{\text{water}})^{-1}$, and where $\Delta r_L = r_{L \text{ final}} - r_{L \text{ initial}}$ is negative for evaporation. This parcel cooling enters the downdraft-velocity equation via θ_{parcel} in eq. (15.6).

Precipitation drag is usually a smaller effect than evaporative cooling. Fig. 15.12 shows both the precipitation-drag effect for different initial liquid-water mixing ratios (the black dots), and the corresponding cooling and liquid-water decrease as the drops evaporate. For example, consider the black dot corresponding to an initial liquid water loading of 10 g kg^{-1} . Even before that drop evaporates, the weight of the rain decreases the virtual potential temperature by about 2.9°C . However, as that drop evaporates, it causes a much larger amount of cooling to due latent heat absorption, causing the virtual-potential-temperature to decrease by 25°C after it has completely evaporated.

Evaporative cooling can be large in places where the environmental air is dry, such as in the high-altitude plains and prairies of the USA and Canada. There, raining convective clouds can create strong downbursts, even if all the precipitation evaporates before reaching the ground (i.e., for **virga**).

Downbursts are hazardous to aircraft in two ways. (1) The downburst speed can be faster than the climb rate of the aircraft, pushing the aircraft towards the ground. (2) When the downburst hits the ground and spreads out, it can create hazardous changes between headwinds and tailwinds for landing and departing aircraft (see the “Aircraft vs. Downbursts” INFO Box in this section.) Modern airports are equipped with Doppler radar and/or wind-sensor arrays on the airport grounds, so that warnings can be given to pilots.

15.2.4. Downdraft CAPE (DCAPE)

Eq. (15.5) applies at any one altitude. As precipitation-laden air parcels descend, many things change. The descending air parcel cools and loses some of its liquid-water loading due to evaporation, thereby changing its virtual potential temperature. It descends into surroundings having different virtual potential temperature than the environment where it started. As a result of these changes to both the air parcel and its environment, the θ_v' term in eq. (15.5) changes.

To account for all these changes, find term B from eq. (15.5) at each depth, and then sum over all depths to get the accumulated effect of evaporative cooling and precipitation drag. This is a difficult calculation, with many uncertainties.

An alternative estimate of downburst strength is via the **Downdraft Convective Available Potential Energy (DCAPE)**, see shaded area in Fig. 15.13):

$$DCAPE = \sum_{z=0}^{z_{LFS}} |g| \frac{\theta_{vp} - \theta_{ve}}{\theta_{ve}} \Delta z \quad \bullet(15.9)$$

where $|g| = 9.8 \text{ m s}^{-2}$ is the magnitude of gravitational acceleration, θ_{vp} is the parcel virtual potential temperature (including temperature, water vapor, and precipitation-drag effects), θ_{ve} is the environment virtual potential temperature (Kelvin in the denominator), Δz is a height increment to be used when conceptually covering the DCAPE area with tiles of equal size.

The altitude z_{LFS} where the precipitation-laden air first becomes negatively buoyant compared to the environment is called the **level of free sink (LFS)**, and is the downdraft equivalent of the level of free convection. If the downburst stays negatively buoyant to the ground, then the bottom limit of the sum is at $z = 0$, otherwise the downburst would stop at a **downdraft equilibrium level (DEL)** and not be felt at the ground. DCAPE is negative, and has units of J kg^{-1} or $\text{m}^2 \text{ s}^{-2}$.

By relating potential energy to kinetic energy, the downdraft velocity is approximately:

$$w_{max\ down} = -(2 \cdot |DCAPE|)^{1/2} \quad (15.10)$$

Air drag of the descending air parcel against its surrounding environmental air could reduce the likely downburst velocity w_d to about half this max value (Fig. 15.14):

$$w_d = w_{max\ down} / 2 \quad \bullet(15.11)$$

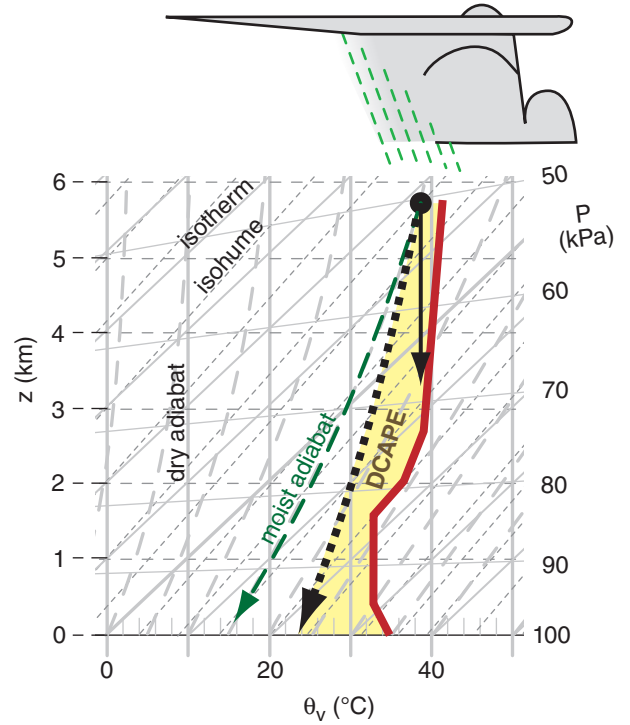

Figure 15.13
Thermo diagram (Theta-z diagram from the Stability chapter) example of Downdraft Convective Available Potential energy (DCAPE, yellow shaded area). Thick solid red line is environmental sounding. Black dot shows virtual potential temperature after top of environmental sounding has been modified by liquid-water loading caused by precipitation falling into it from above. Three scenarios of rain-filled air-parcel descent are shown: (a) no evaporative cooling, but only constant liquid water loading (thin solid line following a dry adiabat); (b) an initially saturated air parcel with evaporative cooling of the rain (dashed green line following a moist adiabat); and (c) partial evaporation (thick dotted black line) with a slope between the moist and dry adiabats.

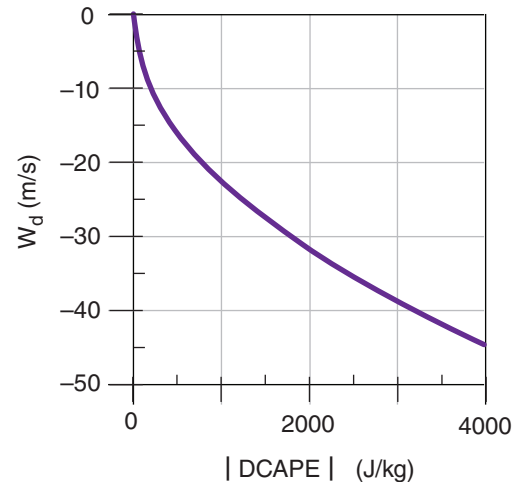

Figure 15.14
Downburst velocity w_d driven by DCAPE

Sample Application

For the shaded area in Fig. 15.13, use the tiling method to estimate the value of DCAPE. Also find the maximum downburst speed and the likely speed.

Find the Answer

Given: Fig. 15.13, reproduced here.

Find: $DCAPE = ? \text{ m}^2 \text{ s}^{-2}$,

$$w_{max\ down} = ? \text{ m s}^{-1} \quad w_d = ? \text{ m s}^{-1}$$

The DCAPE equation (15.9) can be re-written as

$$DCAPE = -[|g|/\theta_{ve}] \cdot (\text{shaded area})$$

Method: Overlay the shaded region with tiles:

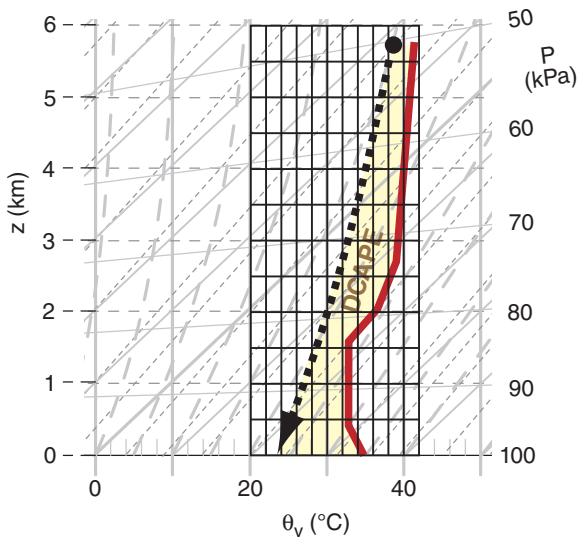

Each tile is $2^\circ\text{C} = 2 \text{ K}$ wide by 0.5 km tall (but you could pick other tile sizes instead). Hence, each tile is worth $1000 \text{ K}\cdot\text{m}$. I count approximately 32 tiles needed to cover the shaded region. Thus:

$$(\text{shaded area}) = 32 \times 1000 \text{ K}\cdot\text{m} = 32,000 \text{ K}\cdot\text{m}$$

Looking at the plotted environmental sounding by eye, I estimate the average $\theta_{ve} = 37^\circ\text{C} = 310 \text{ K}$.

$$DCAPE = -[(9.8 \text{ m s}^{-2})/310\text{K}] \cdot (32,000 \text{ K}\cdot\text{m}) \\ = -1012 \text{ m}^2 \text{ s}^{-2}$$

Next, use eq. (15.10):

$$w_{max\ down} = -[2 \cdot |-1012 \text{ m}^2 \text{ s}^{-2}|]^{1/2} \\ = -45 \text{ m s}^{-1}$$

Finally, use eq. (15.11):

$$w_d = w_{max\ down}/2 = -22.5 \text{ m s}^{-1}$$

Check: Units OK. Physics OK. Drawing OK.

Exposition: While this downburst speed might be observed 1 km above ground, the speed would diminish closer to the ground due to an opposing pressure-perturbation gradient. Since the DCAPE method doesn't account for the vertical pressure gradient, it shouldn't be used below about 1 km altitude.

Stronger downdrafts and associated straight-line winds near the ground are associated with larger magnitudes of DCAPE. For example, Fig. 15.15 shows a case study of DCAPE magnitudes valid at 22 UTC on 24 May 2006.

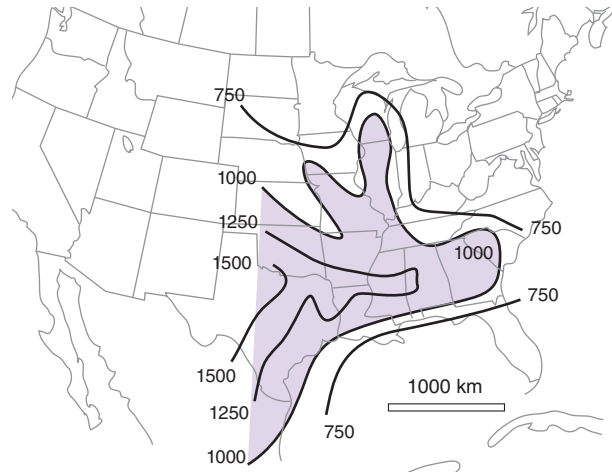

Figure 15.15

Example of downdraft DCAPE magnitude (J kg^{-1}) for 22 UTC 24 May 06 over the USA.

INFO • CAPE vs. DCAPE

Although DCAPE shares the same conceptual framework as CAPE, there is virtually no chance of practically utilizing DCAPE, whereas CAPE is very useful. Compare the two concepts.

For CAPE: The initial state of the rising air parcel is known or fairly easy to estimate from surface observations and forecasts. The changing thermodynamic state of the parcel is easy to anticipate; namely, the parcel rises dry adiabatically to its LCL, and rises moist adiabatically above the LCL with vapor always close to its saturation value. Any excess water vapor instantly condenses to keep the air parcel near saturation. The resulting liquid cloud droplets are initially carried with the parcel.

For DCAPE: Both the initial air temperature of the descending air parcel near thunderstorm base and the liquid-water mixing ratio of raindrops are unknown. The raindrops don't move with the air parcel, but pass through the air parcel from above. The air parcel below cloud base is often NOT saturated even though there are raindrops within it. The temperature of the falling raindrops is often different than the temperature of the air parcel it falls through. There is no requirement that the adiabatic warming of the air due to descent into higher pressure be partially matched by evaporation from the rain drops (namely, the thermodynamic state of the descending air parcel can be neither dry adiabatic nor moist adiabatic).

Unfortunately, the exact thermodynamic path traveled by the descending rain-filled air parcel is unknown, as discussed in the INFO box. Fig. 15.13 illustrates some of the uncertainty in DCAPE. If the rain-filled air parcel starting at pressure altitude of 50 kPa experiences no evaporation, but maintains constant precipitation drag along with dry adiabatic warming, then the parcel state follows the thin solid arrow until it reaches its DEL at about 70 kPa. This would not reach the ground as a down burst.

If a descending saturated air parcel experiences just enough evaporation to balance adiabatic warming, then the temperature follows a moist adiabat, as shown with the thin dashed line. But it could be just as likely that the air parcel follows a thermodynamic path in between dry and moist adiabat, such as the arbitrary dotted line in that figure, which hits the ground as a cool but unsaturated downburst.

15.2.5. Pressure Perturbation

As the downburst approaches the ground, its vertical velocity must decelerate to zero because it cannot blow through the ground. This causes the dynamic pressure to increase (P' becomes positive) as the air stagnates.

Rewriting Bernoulli's equation (see the Regional Winds chapter) using the notation from eq. (15.5), the maximum stagnation pressure perturbation P'_{max} at the ground directly below the center of the downburst is:

$$P'_{max} = \rho \cdot \left[\frac{w_d^2}{2} - \frac{|g| \cdot \theta'_v \cdot z}{\theta_{ve}} \right] \quad \bullet(15.12)$$

Term: (A) (B)

where ρ is air density, w_d is likely peak downburst speed at height z well above the ground (before it feels the influence of the ground), $|g| = 9.8 \text{ m s}^{-2}$ is gravitational acceleration magnitude, and virtual potential temperature depression of the air parcel relative to the environment is $\theta'_v = \theta_{v \text{ parcel}} - \theta_{ve}$.

Term (A) is an inertial effect. Term (B) includes the role of the added weight of cold air (with possible precipitation loading) in increasing the pressure [because θ'_v is usually (but not always) negative in downbursts]. Both effects create a mesoscale high (**mesohigh**, \mathbb{H}) pressure region centered on the downburst. Fig. 15.16 shows the solution to eq. (15.12) for a variety of different downburst velocities

Sample Application

A downburst has velocity -22 m s^{-1} at 1 km altitude, before feeling the influence of the ground. Find the corresponding perturbation pressure at ground level for a downburst virtual potential temperature perturbation of (a) 0, and (b) -5°C .

Find the Answer:

Given: $w_d = -22 \text{ m s}^{-1}$, $z = 1 \text{ km}$, $\theta'_v =$ (a) 0, or (b) -5°C
 Find: $P'_{max} = ? \text{ kPa}$

Assume standard atmosphere air density at sea level $\rho = 1.225 \text{ kg m}^{-3}$

Assume $\theta_{ve} = 294 \text{ K}$. Thus $|g|/\theta_{ve} = 0.0333 \text{ m}\cdot\text{s}^{-2}\cdot\text{K}^{-1}$
 Use eq. (15.12):

(a) $P'_{max} = (1.225 \text{ kg m}^{-3}) \cdot [(-22 \text{ m s}^{-1})^2/2 - 0]$
 $= 296 \text{ kg}\cdot\text{m}^{-1}\cdot\text{s}^{-2} = 296 \text{ Pa} = \mathbf{0.296 \text{ kPa}}$

(b) $\theta'_v = -5^\circ\text{C} = -5 \text{ K}$ because it represents a temperature difference.

$P'_{max} = (1.225 \text{ kg m}^{-3}) \cdot [(-22 \text{ m s}^{-1})^2/2 - (0.0333 \text{ m}\cdot\text{s}^{-2}\cdot\text{K}^{-1}) \cdot (-5 \text{ K}) \cdot (1000 \text{ m})]$
 $P'_{max} = [296 + 204] \text{ kg}\cdot\text{m}^{-1}\cdot\text{s}^{-2} = 500 \text{ Pa} = \mathbf{0.5 \text{ kPa}}$

Check: Units OK. Physics OK. Agrees with Fig. 15.16.

Exposition: For this case, the cold temperature of the downburst causes P' to nearly double compared to pure inertial effects. Although P'_{max} is small, P' decreases to 0 over a short distance, causing large $\Delta P'/\Delta x$ & $\Delta P'/\Delta z$. These large pressure gradients cause large accelerations of the air, including the rapid deceleration of the descending downburst air, and the rapid horizontal acceleration of the same air to create the outflow winds.

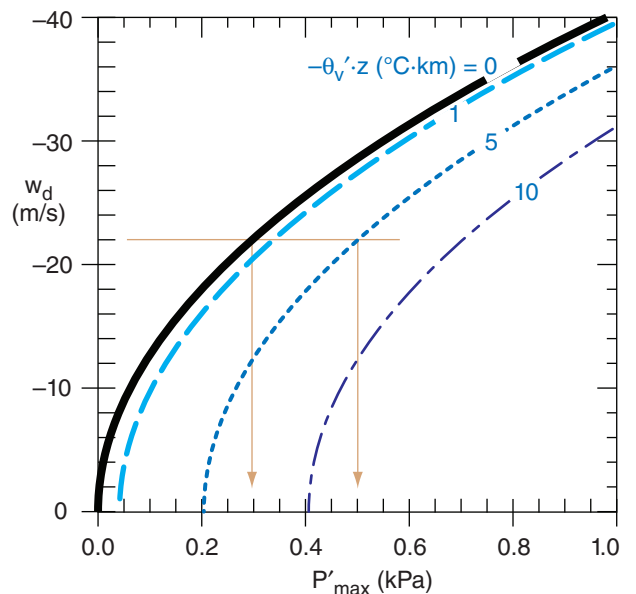

Figure 15.16

Descending air of velocity w_d decelerates to zero when it hits the ground, causing a pressure increase P'_{max} at the ground under the downburst compared to the surrounding ambient atmosphere. For descending air of the same temperature as its surroundings, the result from Bernoulli's equation is plotted as the thick solid black line. If the descending air is also cold (i.e., has some a virtual potential temperature deficit $-\theta'_v$ at starting altitude z), then the blue curves show how the pressure perturbation increases further.

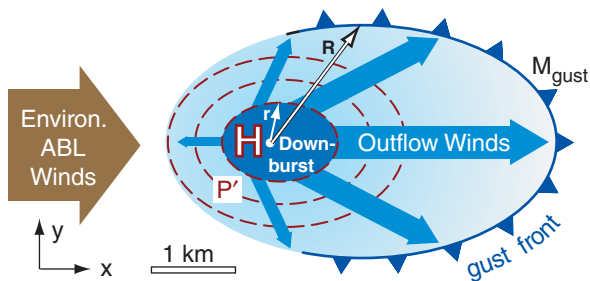

Figure 15.17

Horizontal slice through the air just above the ground, corresponding to Fig. 15.11. Shown are the downburst of average radius r (dark blue), gust front of average radius R (blue arc, with cold-frontal symbols [triangles]), cool air (gradient shaded light blue), and outflow winds (thick blue arrows) flowing in straight lines. H shows the location of a meso-high-pressure center near the ground, and the dashed red lines show isobars of positive perturbation pressure P' .

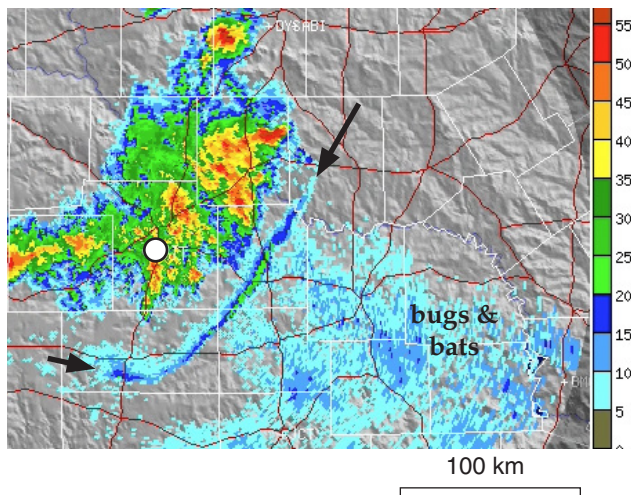

Figure 15.18

Radar reflectivity from the San Angelo (SJT), Texas, USA, weather radar. White circle shows radar location. Thunderstorm cells with heavy rain (red & yellow) are over and north-east of the radar. Arrows show ends of gust front. Scale at right is radar reflectivity in dBZ. Radar elevation angle is 0.5° . Both figs. courtesy of the National Center for Atmospheric Research, based on National Weather Service radar data, NOAA.

and virtual potential temperature deficits. Typical magnitudes are on the order of 0.1 to 0.6 kPa (or 1 to 6 mb) higher than the surrounding pressure.

As you move away vertically from the ground and horizontally from the downburst center, the pressure perturbation decreases, as suggested by the dashed line isobars in Figs. 15.11 and 15.17. The vertical gradient of this pressure perturbation decelerates the downburst near the ground. The horizontal gradient of the pressure perturbation accelerates the air horizontally away from the downburst, thus preserving air-mass continuity by balancing vertical inflow with horizontal **outflow** of air.

15.2.6. Outflow Winds & Gust Fronts

Driven by the pressure gradient from the meso-high, the near-surface **outflow** air tends to spread out in all directions radially from the downburst. It can be enhanced or reduced in some directions by background winds (Fig. 15.17). **Straight-line** outflow winds (i.e., non-tornadic; non-rotating) behind the gust front can be as fast as 35 m s^{-1} , and can blow down trees and destroy mobile homes. Such winds can make a howling sound called **aeolian tones**, as wake eddies form behind wires and twigs.

The outflow winds are accelerated by the perturbation-pressure gradient associated with the downburst mesohigh. Considering only the horizontal pressure-gradient force in Newton's 2nd Law (see the Forces & Winds Chapter), you can estimate the acceleration from

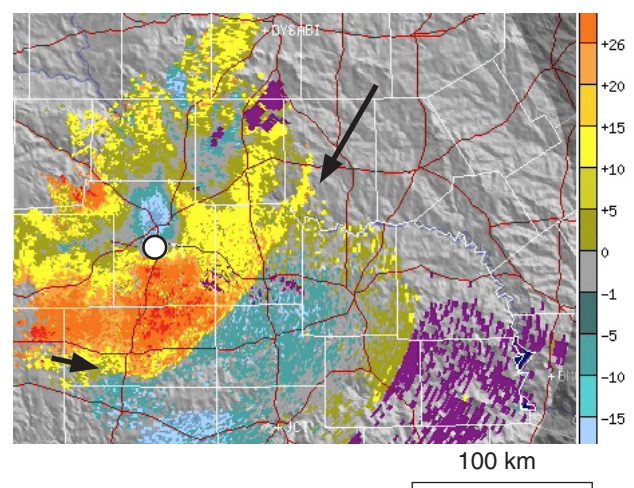

Figure 15.19

Same as 15.18, but for Doppler velocity. Red, orange, and yellow colors are winds away from the radar (white circle), and light blue and turquoise are winds towards. Scale at right is speed in knots.

$$\frac{\Delta M}{\Delta t} = \frac{1}{\rho} \frac{P'_{max}}{r} \quad \bullet(15.13)$$

where ΔM is change of outflow wind magnitude over time interval Δt , ρ is air density, P'_{max} is the pressure perturbation strength of the mesohigh, and r is the radius of the downburst (assuming it roughly equals the radius of the mesohigh).

The horizontal **divergence signature** of air from a downburst can be detected by Doppler weather radar by the couplet of “toward” and “away” winds, as was shown in the Satellites & Radar chapter. Figs. 15.18 and 15.19 show a downburst divergence signature and gust front.

Downburst intensity (Table 15-2) can be estimated from the maximum radial wind speed M_{max} observed by Doppler radar in the divergence couplet, and from the max change of wind speed ΔM_{max} along a radial line extending out from the radar at any height below 1 km above mean sea level (MSL).

Gust front is the name given to the leading edge of the cold **outflow** air (Figs. 15.11 & 15.17). These fronts act like shallow (100 to 1000 m thick) cold fronts, but with lifetimes of only several minutes to a few hours. Gust fronts can advance at speeds ranging from 5 to 15 m s⁻¹, and their length can be 5 to 100 km. The longer-lasting gust fronts are often associated with squall lines or supercells, where downbursts of cool air from a sequence of individual cells can continually reinforce the gust front.

Temperature drops of 1 to 3 °C have been recorded as a gust front passes a weather station. As this cold, dense air plows under warmer, less-dense humid air in the pre-storm environmental atmospheric boundary layer (ABL), the ABL air can be pushed up out of the way. If pushed above its LCL, clouds can form in this ABL air, perhaps even triggering new thunderstorms (a process called **propagation**). The new storms can develop their own gust fronts that can trigger additional thunderstorms, resulting in a storm sequence that can span large distances.

Greater gust front speeds are expected if faster downbursts pump colder air toward the ground. The continuity equation tells us that the vertical inflow rate of cold air flowing down toward the ground in the downburst must balance the horizontal outflow rate behind the gust front. If we also approximate the outflow thickness, then we can estimate the speed M_{gust} of advance of the gust front relative to the ambient environmental air as

$$M_{gust} = \left[\frac{0.2 \cdot r^2 \cdot |w_d \cdot g \cdot \Delta T_v|}{R \cdot T_{ve}} \right]^{1/3} \quad (15.14)$$

where r is average downburst radius, R is average distance of the gust front from the downburst center, w_d is downburst speed, ΔT_v is virtual tempera-

Sample Application

For a mesohigh of max pressure 0.5 kPa and radius 5 km, how fast will the outflow winds become during 1 minute of acceleration?

Find the Answer

Given: $P'_{max} = 0.5 \text{ kPa}$, $r = 5 \text{ km}$, $\Delta t = 60 \text{ s}$

Find: $\Delta M = ? \text{ m s}^{-1}$

Solve eq. (15.13) for M . Assume $\rho = 1.225 \text{ kg m}^{-3}$.

$$\Delta M = \frac{(60 \text{ s})}{(1.225 \text{ kg/m}^3)} \cdot \frac{(0.5 \text{ kPa})}{(5 \text{ km})} = \mathbf{4.9 \text{ m s}^{-1}}$$

Check: Physics OK. Units OK. Magnitude OK.

Exposition: In real downbursts, the pressure gradient varies rapidly with time and space. So this answer should be treated as only an order-of-magnitude estimate.

Table 15-2. Doppler-radar estimates of thunderstorm-cell downburst intensity based on either the maximum outflow wind speed or the maximum wind difference along a radar radial.

Intensity	Max radial-wind speed (m s ⁻¹)	Max wind difference along a radial (m s ⁻¹)
Moderate	18	25
Severe	25	40

Sample Application

A thunderstorm creates a downburst of speed of 4 m s^{-1} within an area of average radius 0.6 km . The gust front is 3°C colder than the environment air of 300 K , and is an average of 2 km away from the center of the downburst. Find the gust-front advancement speed and depth.

Find the Answer

Given: $\Delta T_v = -3 \text{ K}$, $T_{ve} = 300 \text{ K}$, $w_d = -4 \text{ m s}^{-1}$,
 $r = 0.6 \text{ km}$, $R = 2 \text{ km}$,

Find: $M_{gust} = ? \text{ m s}^{-1}$, $h_{gust} = ? \text{ m}$

Employ eq. (15.14): $M_{gust} =$

$$\left[\frac{0.2 \cdot (600 \text{ m})^2 \cdot |(-4 \text{ m/s}) \cdot (-9.8 \text{ m}\cdot\text{s}^{-2}) \cdot (-3 \text{ K})|}{(2000 \text{ m}) \cdot (300 \text{ K})} \right]^{1/3}$$

$= \underline{2.42 \text{ m s}^{-1}}$

Employ eq. (15.15): $h_{gust} =$

$$0.85 \left[\left(\frac{(-4 \text{ m/s}) \cdot (600 \text{ m})^2}{(2000 \text{ m})} \right)^2 \frac{(300 \text{ K})}{|(-9.8 \text{ m}\cdot\text{s}^{-2}) \cdot (-3 \text{ K})|} \right]^{1/3}$$

$= \underline{174 \text{ m}}$

Check: Units OK. Physics OK.

Exposition: Real gust fronts are more complicated than described by these simple equations, because the outflow air can turbulently mix with the environmental ABL air. The resulting mixture is usually warmer, thus slowing the speed of advance of the gust front.

ture difference between the cold-outflow and environmental air, and T_{ve} (K) is the environmental virtual temperature.

In the expression above, the following approximation was used for gust-front thickness h_{gust} :

$$h_{gust} \approx 0.85 \left[\frac{T_{ve}}{|g \cdot \Delta T_v|} \left(\frac{w_d \cdot r^2}{R} \right)^2 \right]^{1/3} \quad (15.15)$$

As the gust front spreads further from the downburst, it moves more slowly and becomes shallower. Also, colder outflow air moves faster in a shallower outflow than does less-cold outflow air.

In dry environments, the fast winds behind the gust front can lift soil particles from the ground (a process called **saltation**). While the heavier sand particles fall quickly back to the ground, the finer dust particles can become **suspended within** the air. The resulting dust-filled outflow air is called a **haboob** (Fig. 15.20), **sand storm** or **dust storm**. The airborne dust is an excellent tracer to make the gust front visible, which appears as a turbulent advancing wall of brown or ochre color.

In moister environments over vegetated or rain-wetted surfaces, instead of a haboob you might see **arc cloud** (**arcus**) or **shelf cloud** over (not within) an advancing gust front. The arc cloud forms when the warm humid environmental ABL air is pushed upward by the undercutting cold outflow air. Sometimes the top and back of the arc cloud are connected or almost connected to the thunderstorm, in which case the cloud looks like a shelf attached to the thunderstorm, and is called a **shelf cloud**.

When the arc cloud moves overhead, you will notice sudden changes. Initially, you might observe the warm, humid, fragrant boundary-layer air that was blowing toward the storm. After gust-front passage, you might notice colder, gusty, sharp-smelling (from ozone produced by lightning discharges) downburst air.

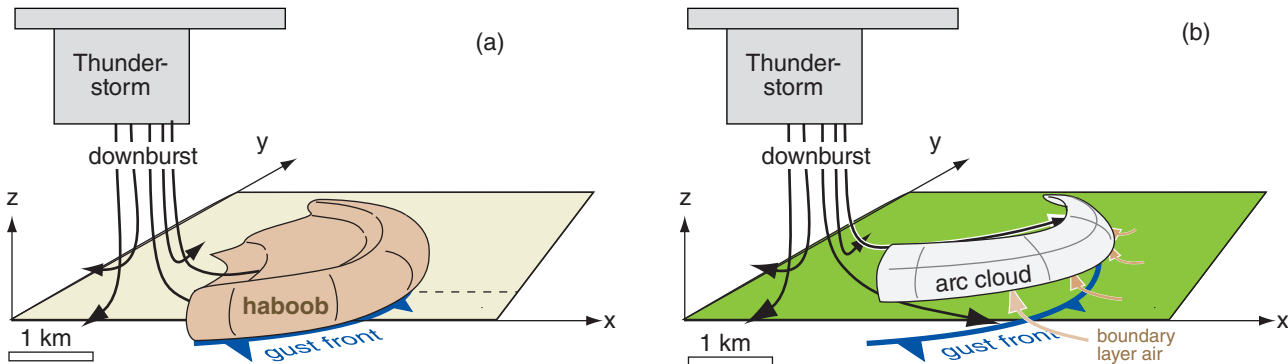

Figure 15.20 Sketches of (a) a haboob (dust storm) kicked up within the outflow winds, and (b) an arc cloud in the boundary-layer air pushed above the leading edge of the outflow winds (i.e., above the gust front). Haboobs occur in drier locations. Arc clouds occur in humid locations.

15.3. LIGHTNING AND THUNDER

Lightning (Fig. 15.21) is an electrical discharge (spark) between one part of a cloud and either:

- another part of the same cloud
[intracloud (IC) lightning],
- a different cloud
[cloud-to-cloud (CC) lightning, or intercloud lightning],
- the ground or objects touching the ground
[cloud-to-ground (CG) lightning], or
- the air
[cloud-to-air discharge (CA)].

Other weak high-altitude electrical discharges (blue jets, sprites and elves) are discussed later.

The lightning discharge heats the air almost instantly to temperatures of 15,000 to 30,000 K in a **lightning channel** of small diameter (2 to 3 cm) but long path (0.1 to 10 km). This heating causes:

- incandescence of the air, which you see as a bright flash, and
- a pressure increase to values in the range of 1000 to 10,000 kPa in the channel, which you hear as thunder.

On average, there are about 2000 thunderstorms active at any time in the world, resulting in about 45 flashes per second. Worldwide, there are roughly 1.4×10^9 lightning flashes (IC + CG) per year, as de-

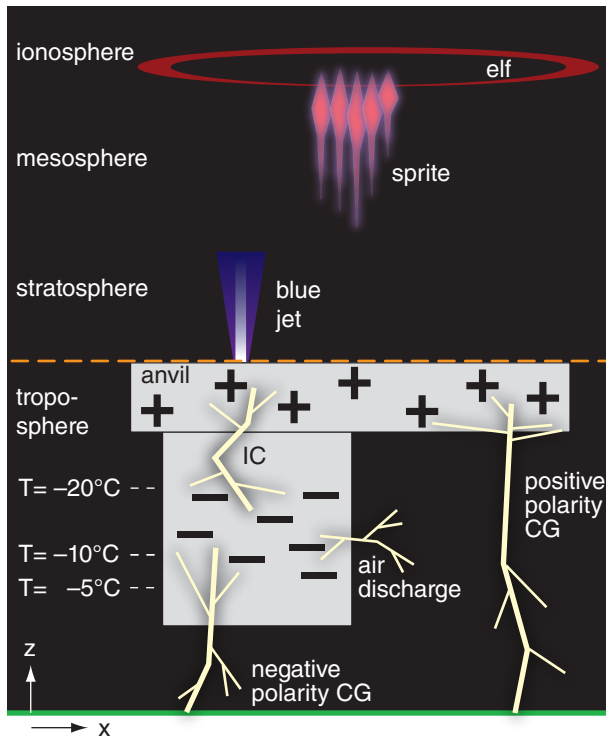

Figure 15.21
Types of lightning. Grey rectangles represent the thunderstorm cloud. (Vertical axis not to scale.)

INFO • Aircraft vs. Downbursts

113 people died in 1975 when a commercial jet flew through a downburst while trying to land at J. F. Kennedy airport near New York City.

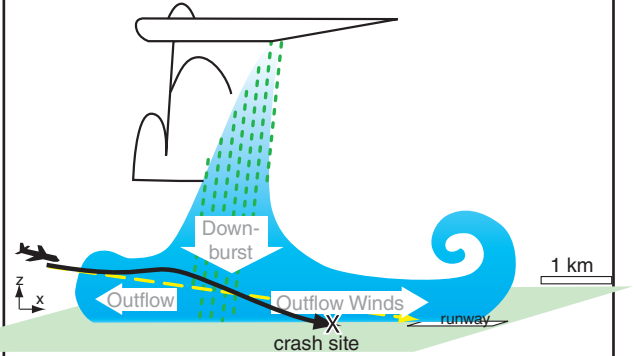

Figure 15.a
Sketch of the actual (solid line) and desired (dashed line) approach of the aircraft to a runway at JFK airport during a downburst event. Dotted green lines represent rain; light blue shading represents the downburst and outflow air.

The airliner first encountered outflow headwinds while trying to gradually descend along the normal glideslope (dashed line) toward the runway. Due to the aircraft's forward inertia, the headwinds caused more air to blow over wings, generating more lift. This extra lift caused the aircraft to unintentionally climb (or not descend as fast), as shown by the solid line representing the actual aircraft path.

To compensate, the pilot slowed the engines and pointed the aircraft more downward, to try to get back down to the desired glideslope. But then the plane flew through the downburst, pushing the aircraft downward below the glideslope. So the pilot had to compensate in the opposite direction, by throttling up the engines to full power and raising the nose of the aircraft to try to climb back up to the glideslope.

By this time, the aircraft had reached the other side of the downburst, where the outflow winds were moving in the same direction as the aircraft. Relative to the aircraft, there was less air flowing over the wings and less lift, allowing gravity to pull the aircraft down even faster. The pilot increased pitch and engine power, but the turbine engines took a few seconds to reach full power. The inertia of the heavy aircraft caused its speed to increase too slowly. The slow airspeed and downward force of the downburst caused the aircraft to crash short of the runway.

That crash motivated many meteorological field experiments to enable better detection and forecasts of downbursts and gust fronts. Airports have special equipment (anemometers and Doppler radar) to detect dangerous wind shears; air-traffic controllers have a protocol to alert pilots and direct them to safety; and pilots are trained to carry extra speed and make earlier **missed-approach** decisions.

INFO • Electricity in a Channel

Electricity is associated with the movement of electrons and ions (charged particles). In metal channels such as electrical wires, it is usually only the electrons (negative charges) that move. In the atmospheric channels such as lightning, both negative and positive ions can move, although electrons can move faster because they are smaller, and carry most of the current. Lightning forms when **static electricity** in clouds discharges as **direct current** (DC).

Each electron carries one elementary negative charge. One **coulomb** (C) is an **amount of charge** (Q) equal to 6.24×10^{18} elementary charges. [Don't confuse C (coulombs) with °C (degrees Celsius).] The **main charging zone** of a thunderstorm is between altitudes where $-20 \leq T \leq -5^\circ\text{C}$ (Fig. 15.21), where typical thunderstorms hold 10 to 100 coulombs of static charge.

The movement of 1 C of charge per 1 second (s) is a **current** (I) of 1 A (**ampere**).

$$I = \Delta Q / \Delta t \quad (\text{ec1})$$

The median current in lightning is 25 kA.

Most substances offer some **resistance** (R) to the movement of electrical charges. Resistance between two points along a wire or other conductive channel is measured in **ohms** (Ω).

An electromotive force (V , better known as the **electrical potential difference**) of 1 V (**volt**) is needed to push 1 A of electricity through 1 ohm of resistance.

$$V = I \cdot R \quad (\text{ec2})$$

[We use italicized V to represent the variable (electrical potential), and non-italicized V for its units (volts).]

The **power** P_e (in watts W) spent to push a current I with voltage V is

$$P_e = I \cdot V \quad (\text{ec3})$$

where $1 \text{ W} = 1 \text{ V} \cdot 1 \text{ A}$. For example, lightning of voltage $1 \times 10^9 \text{ V}$ and current 25 kA dissipates $2.5 \times 10^{13} \text{ W}$.

A lightning stroke might exist for $\Delta t = 30 \mu\text{s}$, so the energy moved is $P_e \cdot \Delta t = (2.5 \times 10^{13} \text{ W}) \cdot (0.00003 \text{ s}) = 7.5 \times 10^8 \text{ J}$; namely, about 0.75 billion Joules.

tected by optical transient detectors on satellites. Africa has the greatest amount of lightning, with 50 to 80 flashes $\text{km}^{-2} \text{ yr}^{-1}$ over the Congo Basin. In North America, the region having greatest lightning frequency is the Southeast, having 20 to 30 flashes $\text{km}^{-2} \text{ yr}^{-1}$, compared to only 2 to 5 flashes $\text{km}^{-2} \text{ yr}^{-1}$ across most of southern Canada.

On average, only 20% of all lightning strokes are CG, as measured using ground-based lightning detection networks, but the percentage varies with cloud depth and location. The fraction of lightning that is CG is less than 10% over Kansas, Nebraska, the Dakotas, Oregon, and NW California, and is about 50% over the Midwest states, the central and southern Rocky Mountains, and eastern California.

CG lightning causes the most deaths, and causes power surges or disruptions to electrical transmission lines. In North America, the southeastern states have the greatest density of CG lightning [4 to 10 flashes $\text{km}^{-2} \text{ yr}^{-1}$]. Tampa, Florida, has the greatest CG flash density of 14.5 flashes $\text{km}^{-2} \text{ yr}^{-1}$.

Most CG lightning causes the transfer of electrons (i.e., negative charge) from cloud to ground, and is called **negative-polarity** lightning. About 9% of CG lightning is **positive-polarity**, and usually is attached to the thunderstorm anvil (Fig. 15.21) or to the extensive stratiform region of a mesoscale convective system. Because positive-polarity lightning has a longer path (to reach between anvil and ground), it requires a greater voltage gradient. Thus, positive CG lightning often transfers more charge with greater current to the ground, with a greater chance of causing deaths and **forest fires**.

15.3.1. Origin of Electric Charge

Large-scale (macroscale) **cloud electrification** occurs due to small scale (microphysical) interactions between individual cloud particles. Three types of particles are needed in the same volume of cloud:

- small ice crystals formed directly by deposition of vapor onto ice nuclei;
- small supercooled liquid water (cloud) droplets;
- slightly larger graupel ice particles.

An updraft is also needed to blow the small particles upward relative to the larger ones falling down.

These three conditions can occur in cumulonimbus clouds at altitudes where temperature is between 0°C and -40°C . However, most of the electrical charge generation is observed to occur at heights where the temperature ranges between -5 and -20°C (Fig. 15.21).

The details of how charges form are not known with certainty, but one theory is that the falling graupel particles intercept lots of supercooled cloud

droplets that freeze relatively quickly as a glass. [Definitions: A **glass** is a state of solid material in which the molecules have random arrangement. A **crystal** has an ordered lattice of molecules.] Meanwhile, separate ice nuclei allow the growth of ice crystals by direct deposition of vapor. The alignment of water molecules on these two types of surfaces (glass vs. crystal) are different, causing different arrangement of electrons near the surface. Ice crystals tend to have negative charges at the tips of the crystal arms.

If one of the small ice crystals (being blown upward in the updraft because of its small terminal velocity) hits a larger graupel particle (heavier and falling downward relative to the updraft air), then about 100,000 electrons (a charge of about 1.5×10^{-14} C) will transfer from the small ice crystal (leaving the ice crystal positively charged) to the larger glass-surfaced graupel particle (leaving it negatively charged) during this one collision (Fig. 15.22). This is the microphysical electrification process.

In 1 km^3 of thunderstorm air, there can be on the order of 5×10^{13} collisions of graupel and ice crystals per minute. The lighter-weight ice crystals carry their positive charge with them as they are blown in the updraft to the top of the thunderstorm, leading to the net positive charge in the anvil. Similarly, the heavier graupel carry their negative charges to the middle and bottom of the storm. The result is a macroscale (Fig. 15.21) charging rate of the thunderstorm cloud of order $1 \text{ C km}^{-3} \text{ min}^{-1}$. As these charges continue to accumulate, the electric field (i.e., voltage difference) increases between the cloud and the ground, and between the cloud and its anvil.

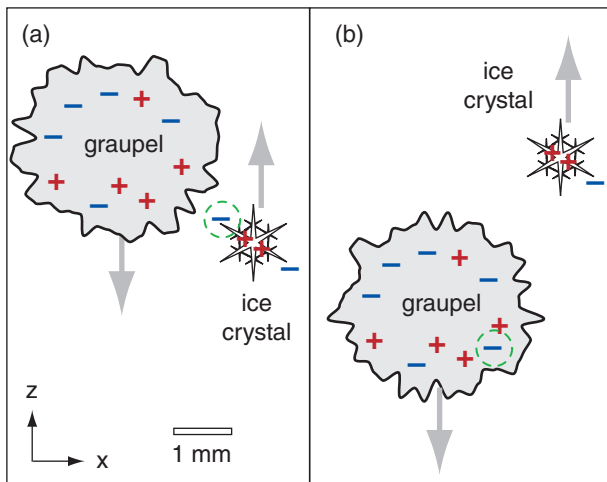

Figure 15.22
 Illustration of charge transfer from a small, neutrally-charged, rising ice crystal to a larger, neutrally-charged, falling graupel or hail stone. The electron being transferred during the collision is circled with a dashed green line. After the transfer, the graupel has net negative charge that it carries down toward the bottom of the thunderstorm, and the ice crystal has net positive charge that it carries up into the anvil.

INFO • Electricity in a Volume

The **electric field strength** (E , which is the magnitude of the **electric field** or the gradient of the **electric potential**) measures the electromotive force (voltage V) across a distance (d), and has units of V m^{-1} or V km^{-1} .

$$E = V / d . \tag{ev1}$$

Averaged over the whole atmosphere, $|E| \approx 1.3 \times 10^5 \text{ V km}^{-1}$ in the vertical. A device that measures electric field strength is called a **field mill**.

Near thunderstorms, the electric field can increase because of the charge build-up in clouds and on the ground surface, yielding electric-potential gradients ($E = 1 \times 10^9$ to $3 \times 10^9 \text{ V km}^{-1}$) large enough to ionize air along a narrow channel, causing lightning. When air is ionized, electrons are pulled off of the originally neutral molecules, creating a **plasma** of charged positive and negative particles that is a good conductor (i.e., low resistivity).

Electrical **resistivity** (ρ_e) is the resistance (R) times the cross-section area (*Area*) of the substance (or other conductive path) through which electricity flows, divided by the distance (d) across which it flows, and has units of $\Omega\text{-m}$.

$$\rho_e = R \cdot \text{Area} / d \tag{ev2}$$

Air near sea level is not a good electrical conductor, and has a resistivity of about $\rho_e = 5 \times 10^{13} \Omega\text{-m}$. One reason why its resistivity is not infinite is that very energetic protons (**cosmic rays**) enter the atmosphere from space and can cause a sparse array of paths of ionized particles that are better conductors. Above an altitude of about 30 km, the resistivity is very low due to ionization of the air by sunlight; this conductive layer (called the **electrosphere**) extends into the ionosphere.

Pure water has $\rho_e = 2.5 \times 10^5 \Omega\text{-m}$, while seawater is an even better conductor with $\rho_e = 0.2 \Omega\text{-m}$ due to dissolved salts.

Vertical **current density** (J) is the amount of electric current that flows vertically through a unit horizontal area, and has units A m^{-2} .

$$J = I / \text{Area} \tag{ev3}$$

In clear air, typical background current densities are 2×10^{-12} to $4 \times 10^{-12} \text{ A m}^{-2}$.

Within a volume, the electric field strength, current density, and resistivity are related by

$$E = J \cdot \rho_e \tag{ev4}$$

Sample Application

What voltage difference is necessary to create a lightning bolt across the dry air between cloud base (at 2 km altitude) and the ground?

Find the Answer

Given: $\Delta z = 2 \text{ km}$, $B = 3 \times 10^9 \text{ V km}^{-1}$

Find: $\Delta V_{\text{lightning}} = ? \text{ V}$

Use eq. (15.16):

$$\Delta V_{\text{lightning}} = (3 \times 10^9 \text{ V km}^{-1}) \cdot (2 \text{ km}) = 6 \times 10^9 \text{ V}$$

Check: Units OK. Physics OK.

Exposition: Six billion volts can cause cardiac arrest, so it is wise to avoid being struck by lightning. High-voltage electrical transmission lines are often about $3.5 \times 10^5 \text{ V}$. Lightning is nearly tied with floods as being the most fatal weather hazard in North America.

INFO • Lightning in Canada

In Canada, 99% of CG strokes have currents less than 100 kA. Summer large-current flashes with negative polarity can have 10 or more strokes, and occur mostly in western Canada. First-stroke peak currents are strongest in winter and in northern Canada.

Positive polarity is observed in about 11% of the CG flashes in E. Canada, and about 17% of the CG flashes in W. Canada. In British Columbia and Yukon about 25% of the CG flashes have positive polarity.

In W. Canada, 89% of the positive CG lightning flashes had only one stroke, while 48% of the negative CG lightning had only one stroke. The average number of strokes per CG flash is 2 to 2.4 for negative polarity CG flashes, and about 1 stroke for positive CG.

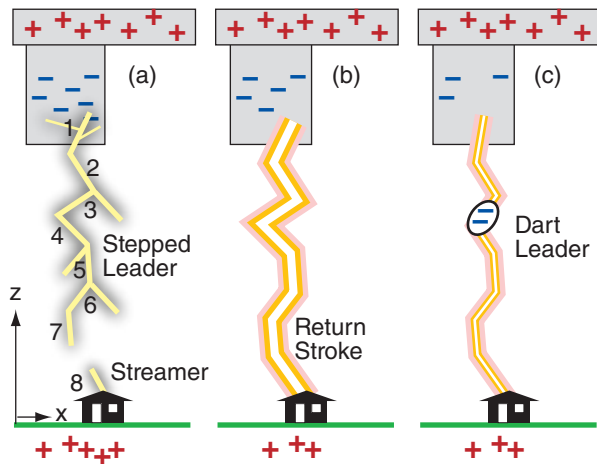

Figure 15.23
Lightning sequence. (a) Stepped leader (1 to 7) moving rapidly down from thunderstorm, triggers upward streamer (8) from objects on ground. (b) Intense return stroke transferring negative charge from the bottom of the thunderstorm to the ground. (c) Dart leader of negative charge following old ionized path toward ground, followed by another return stroke (not shown).

Air is normally a good insulator in the bottom half of the troposphere. For dry air, a voltage gradient of $B_{\text{dry}} = 3 \times 10^9 \text{ V km}^{-1}$ (where V is volts) is needed to ionize the air to make it conductive. For cloudy air, this **breakdown potential** is $B_{\text{cloud}} = 1 \times 10^9 \text{ V km}^{-1}$. Ionization adds/removes electrons to/from the air molecules. If lightning (or any spark) of known length Δz occurs, then you can use the breakdown potential to calculate the voltage difference $\Delta V_{\text{lightning}}$ across the lightning path:

$$\Delta V_{\text{lightning}} = B \cdot \Delta z \quad \bullet(15.16)$$

where B is the dry-air or cloudy-air breakdown potential, depending on the path of the lightning.

15.3.2. Lightning Behavior & Appearance

When sufficient charge builds up in the cloud to reach the breakdown potential, an ionized channel called a **stepped leader** starts to form. It steps downward from the cloud in roughly 50 m increments, each of which takes about $1 \mu\text{s}$ to form, with a pause of about $50 \mu\text{s}$ between subsequent steps (Fig. 15.23). While propagating down, it may branch into several paths. To reach from the cloud to the ground might take hundreds of steps, and take 50 ms duration. For the most common (negative polarity) lightning from the middle of the thunderstorm, this stepped leader carries about 5 C of negative charge downward.

When it is within about 30 to 100 m of the ground or from the top of an object on the ground, its strong negative charge repels free electrons on the ground under it, leaving the ground strongly positively charged. This positive charge causes ground-to-air discharges called **streamers**, that propagate upward as very brief, faintly glowing, ionized paths from the tops of trees, poles, and tall buildings. When the top of a streamer meets the bottom of a top of a stepped leader, the conducting path between the cloud and ground is complete, and there is a very strong (bright) **return stroke** from the ground to the cloud. During this return stroke, electrons drain downward first from the bottom of the stepped leader, and then drain downward from successively higher portions of the channel, producing the flash of light that you see. The stepped leader with return stroke are called a lightning **stroke**. A lightning **strike** is where a stroke hits an object.

Although thunderstorm winds and turbulence tend to rip apart the ionized channel, if the remaining negative charges in the cloud can recollect within about 20 to 50 ms, then another stroke can happen down the same conducting path. This second stroke (and subsequent strokes) forms as a **dart leader** carrying about 1 C of charge that moves smoothly (not

in steps) down the existing channel (with no branches) to the ground, triggering another return stroke. Ten strokes can easily happen along that one ionized channel, and taken together are called a **lightning flash**. The multiple return strokes are what makes a lightning flash appear to flicker.

IC and CG lightning can have different appearances that are sometimes given colloquial names. **Anvil crawlers** or **spider lightning** is IC lightning that propagates with many paths (like spider legs) along the underside of anvils or along the bottom of the stratiform portion of mesoscale convective systems. Some spider lightning is exceptionally long, exceeding 100 km path lengths.

If an IC lightning channel is completely hidden inside a cloud, then often observers on the ground see the whole cloud illuminated as the interior light scatters off the cloud drops (similar to the light emitted from a frosted incandescent light bulb where you cannot see the filament). This is called **sheet lightning**. Lightning from distant thunderstorms may illuminate hazy cloud-free sky overhead, causing dim flashing sky glow called **heat lightning** in the warm, prestorm environment.

A **bolt from the blue** is a form of CG **anvil lightning** that comes out laterally from the side of a storm, and can travel up to 16 km horizontally into clear air before descending to the ground. To people near where this lightning strikes, it looks like it comes from clear blue sky (if they cannot see the thunderstorm that caused it).

Ball lightning is difficult to study, but has been observed frequently enough to be recognized as a real phenomenon. It is rare, but seems to be caused by a normal CG strike that creates a longer lasting (many seconds to minutes) glowing, hissing plasma sphere that floats in the air and moves.

After the last return stroke of CG lightning, the rapidly dimming lightning channel sometimes exhibits a string of bright spots that don't dim as fast as the rest of the channel, and thus appear as a string of glowing beads, called **bead lightning**.

When CG multiple return strokes happen along a lightning channel that is blowing horizontally in the wind, the human eye might perceive the flash as a single broad ribbon of light called **ribbon lightning**. Lightning with a very brief, single return stroke is called **staccato lightning**.

Above the top of strong thunderstorms can be very brief, faint, electrical discharges that are difficult to see from the ground, but easier to see from space or a high-flying aircraft (Fig. 15.21). A **blue jet** is a vertical anvil-to-air discharge into the stratosphere. **Red sprites** can spread between cloud top and about 90 km altitude (in the mesosphere), and have diameters of order 40 km. **Elves** are extremely faint glowing horizontal rings of light at 90 km al-

A SCIENTIFIC PERSPECTIVE • Be Safe (part 3)

More chase guidelines from Charles Doswell III (continued from the previous chapter):

The #2 Threat: Lightning

1. Stay inside your car if cloud-to-ground (CG) lightning is less than 1 mile away.
2. CG threat is high when rain first reaches you.
3. CG can strike well away from the storm. Move to safety. If you can't, then:
 - a. Avoid being the tallest object around.
 - b. Don't stand close to fences or power poles that are connected to wires going closer to the storm.
 - c. Make yourself low (i.e., squat), but don't lay, sit, or kneel on the ground, and don't have your hands touching anything connected to the ground.
 - d. You might not have any warning signs (hear thunder, hear hissing or crackling discharges of electricity nearby, or feel your hair stand on end) before you are struck.
 - e. You and your chase-team members should be trained on how to do **CPR** (cardiopulmonary resuscitation), and should not be afraid to use it immediately if appropriate.
 - f. Non-metallic camera tripods and insulated shoes don't reduce your threat of being struck by lightning.

(continues later in this chapter)

INFO • Lightning Burns the Air

The initial high temperature and pressure inside the lightning channel cause the oxygen in the air to react with the other gases.

Nitrogen, which makes up 78% of the atmosphere (see Chapter 1), oxidizes inside the ionized lightning path to become various oxides of nitrogen (NO_x). During rainout, the NO_x can fall as acid rain (nitric acid), which hurts the plants and acidifies streams and lakes on the short term. But over the long term, the NO_x rained out can help fertilize the soil to encourage plant growth.

Even the oxygen molecules (O_2) can be oxidized within the lightning channel to become ozone (O_3), which we smell in the air as a sharp or fresh odor. Sometimes this odor is carried down and out from the thunderstorm by the downburst and outflow winds, which we can smell when the gust front passes just before the thunderstorm arrives.

Because of all this oxidation, we can say that lightning causes the air to burn.

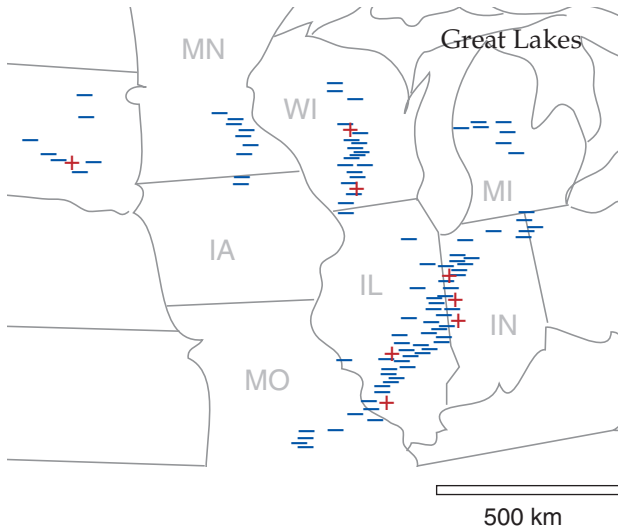

Figure 15.24
Map of negative (–) and positive (+) lightning strikes over the US Midwest from a (simulated) lightning detection network, for the 24 May 2006 case.

titude with radii that increase at the speed of light, centered above strong lightning strokes in thunderstorms. Most people never see these.

15.3.3. Lightning Detection

During a lightning stroke, the changing flow of electricity along the lightning channel creates and broadcasts electromagnetic waves called **sferics**. A broad range of frequencies is transmitted, including radio waves that you hear as static or snaps on AM radio. Detectors on the ground receive these radio signals and accurately measure their strength and time of arrival. Other types of lightning sensors are based on magnetic direction finders.

To pinpoint the location of each lightning strike, a continent-wide array of ground stations observe signals from the same lightning discharge. These ground stations either have direction-finding capability or relative time-of-arrival capability (to infer the range of the strike from the station). Regardless of the station capabilities, the strike is located by triangulating directions or ranges from all the stations that received the signal. All the strike locations during a time interval (5 minutes to a hour) are then plotted on a map (Fig. 15.24). Such an array of detectors on the Earth’s surface and associated communication and computer equipment is called a **lightning detection network (LDN)**.

Some of the sferics are generated at **very low frequencies (VLF)**. Some LDN systems measure these VLF at a frequency of about 10 kHz (wavelength \approx 30 km). The advantage of these VLF waves is that they can travel large distances — trapped in a waveguide between the ionosphere and the ground.

When a VLF wave from lightning passes over an LDN ground station, it modulates the electric field near the station (see the INFO on “Electricity in a Volume”). When multiple stations measure the same wave, the distance D (m) between the lightning and the stations can be estimated, and the peak electric field E (V m^{-1}) measured at any one station can be used to find the approximate peak current I_{max} (A) flowing in the lightning return stroke:

$$I_{max} = -2\pi \cdot \epsilon_0 \cdot c^2 \cdot E \cdot D / v_L \quad (15.17)$$

where $\epsilon_0 = 8.854 \times 10^{-12} \text{ A}\cdot\text{s}\cdot(\text{V}\cdot\text{m})^{-1}$ is the permittivity of free space, $c = 3.00986 \times 10^8 \text{ m s}^{-1}$ is the speed of light, and $v_L = 1.0 \text{ to } 2.2 \times 10^8 \text{ m s}^{-1}$ is the return-stroke current velocity.

The USA has a **National Lightning Detection Network (NLDN)** that typically detects more than 20 million CG flashes per year. Peak electrical currents as high as 400 kA have been rarely observed, but the median peak current is about 25 kA. The average duration of a lightning stroke is about 30

Sample Application

A lightning stroke of max intensity 10 kA occurs 100 km from a detection station. The station would likely measure what electric field value?

Find the Answer

Given: $D = 100 \text{ km}$, $I_{max} = 10 \text{ kA}$,

Find: $E = ? \text{ V m}^{-1}$

Assume: $v_L = 1.5 \times 10^8 \text{ m s}^{-1}$

Rearrange eq. (15.17) to solve for E :

$$E = [-v_L / (2\pi \cdot \epsilon_0 \cdot c^2)] \cdot (I_{max} / D)$$

$$E = [(-1.5 \times 10^8 \text{ m s}^{-1}) / (2\pi \cdot (8.854 \times 10^{-12} \text{ A}\cdot\text{s}\cdot(\text{V}\cdot\text{m})^{-1}) \cdot (3.00986 \times 10^8 \text{ m s}^{-1})^2)] \cdot [(10 \text{ kA}) / 100 \text{ km}] \cdot$$

$$= \underline{-2.98 \text{ V m}^{-1}}$$

Check: Physics and units are OK.

Lightning current flows from high to low voltage (i.e., it flows opposite to the voltage gradient), which is why the answer has a negative sign.

Exposition: Lightning can have positive or negative polarity (i.e., the charge that goes down to the ground). LDN detectors can measure this as well as the waveform of the lightning signal, and are thus able to discriminate between CG and cloud-to-cloud lightning. The net result is that LDNs can provide much valuable information to utility companies and forest fire fighters, including lightning intensity, location, polarity, and type (CG or other).

μs, and the average peak power per stroke is about 10¹² W. One to ten return strokes (with 50 - 300 ms pauses between strokes) can occur in the same ionized path before winds break the path apart.

Satellite systems also detect lightning. Low-light-level video and digital cameras have been on board some satellites and manned space vehicles, and have observed lightning at night from the flashes of light produced. An **optical transient detector (OTD)** has also been deployed that measures the changes in light leaving the portion of atmosphere viewed.

15.3.4. Lightning Forecasting

A dimensionless Cloud Physics Thunder Parameter (CPTP) is defined as:

$$CPTP = (T_o - T_{EL}) \cdot (C_{-20} - C_r) / (T_r \cdot C_r) \quad (15.18)$$

where $T_o = -19^\circ\text{C}$ is an offset temperature, T_{EL} is environmental temperature ($^\circ\text{C}$) at the thunderstorm equilibrium level, $T_r = 1^\circ\text{C}$ is a reference temperature, C_{-20} is the portion of MUCAPE between altitudes where environmental temperatures are 0 and -20°C , and $C_r = 100 \text{ J kg}^{-1}$ is a reference CAPE value. But CPTP is set to 0 if $T_{LCL} \leq -10^\circ\text{C}$. Lightning in thunderstorms is likely when $CPTP \geq 1$.

15.3.5. Lightning Hazards and Safety

When lightning strikes electric power lines it can cause power **surges** (transient spikes in voltage and current in the line). Power surges can ignite electric transformers on power poles, trip circuit breakers and fuses, fry electronics, and electrocute people touching wired appliances.

Based on observations of many such surges, the probability *Prob* that surge current will be greater than I (kA) in the power line is:

$$Prob = \exp \left\{ -0.5 \cdot \left[\frac{\ln((I + I_o) / I_1)}{s_1} \right]^2 \right\} \quad (15.19)$$

for $I \geq (I_1 - I_o)$, where the empirical probability-distribution parameters are $I_o = 2 \text{ kA}$, $I_1 = 3.5 \text{ kA}$, and $s_1 = 1.5$. This curve is plotted in Fig. 15.25 — showing that 50% of these surges exceed about 20 kA.

When a lightning-created surge travels down an electric power line, the voltage (and current) e at any point rapidly increases to its peak value e_{max} and then slowly decays. Electrical engineers approximate this by:

$$e = e_{max} \cdot a \cdot \left[\exp\left(-\frac{t}{\tau_1}\right) - \exp\left(-\frac{t}{\tau_2}\right) \right] \quad (15.20)$$

The nominal constants are: $\tau_1 = 70 \mu\text{s}$, $\tau_2 = 0.15 \mu\text{s}$, and $a = 1.014$. Fig. 15.26 shows a surge that reaches its peak in $1 \mu\text{s}$, and by $50 \mu\text{s}$ has decayed to half.

Sample Application

Suppose the environmental sounding is the same as shown in Fig. 15.7, but where $C_{-20} = 1100 \text{ J kg}^{-1}$ is the portion of MUCAPE between altitudes where the environmental sounding is between 0 and -20°C . Is lightning likely?

Find the Answer

Given: $C_{-20} = 1100 \text{ J kg}^{-1}$

Find: CPTP = ? $^\circ\text{C}$ to determine lightning likelihood.

Inspection of Fig. 15.7 gives $T_{EL} \approx -40^\circ\text{C}$ and $T_{LCL} = 11^\circ\text{C}$.

Since $T_{LCL} > -10^\circ\text{C}$, CPTP is not set to zero. Therefore we must compute it using eq. (15.18):

$$\begin{aligned} CPTP &= [-19 - (-40)]^\circ\text{C} \cdot [(1100 - 100) \text{ J/kg}] / \\ &\quad [1^\circ\text{C} \cdot 100 \text{ J/kg}] \\ &= \mathbf{210} \text{ (dimensionless)} \end{aligned}$$

Since $CPTP \geq 1$, we conclude that

lightning is likely if thunderstorms occur.

Check: Physics and units are OK.

Exposition: Caution: if no thunderstorm occurs, then CPTP is irrelevant. So prediction of lightning also requires prediction of deep convection (CB clouds).

The definition of CPTP is based on the basic ingredients for CB electrification: supercooled liquid water (ensured by $T_{LCL} > -10^\circ\text{C}$); vertical motion in the 0 to -20°C storm region where charge separation occurs (ensured by sufficiently large MUCAPE); and cloud top above the charge-separation region (ensured by $T_{EL} \leq -20^\circ\text{C}$).

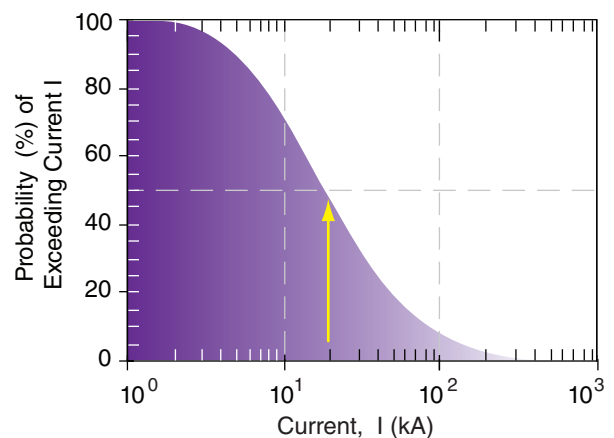

Figure 15.25

This curve (found from eq. 15.19) shows the probability that a surge of current (I) will be exceeded in an electrical power line.

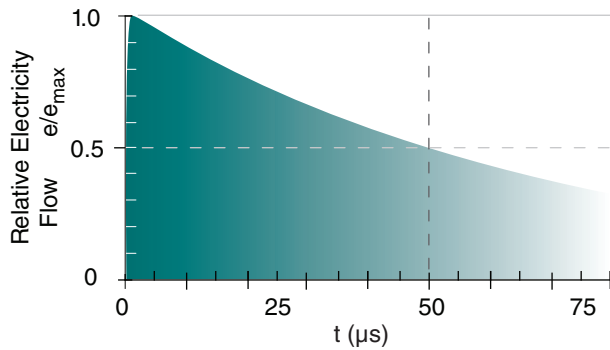

Figure 15.26

The surge of electricity in a power line struck by lightning, where the variable (e) can be applied to current or voltage.

Sample Application

If lightning strikes a power line, what is the probability that the surge current will be 60 kA or greater? When will this surge decay to 5 kA?

Find the Answer

Given: $I = 60$ kA and $I/I_{max} = 5/60 = 0.0833$

Find: $Prob = ? \%$, $t = ? \mu\text{s}$ after the surge starts

Use eq. (15.18):

$$\begin{aligned}
 Prob &= \exp\left\{-0.5\left[\frac{\ln((60+2\text{kA})/(3.5\text{kA}))}{1.5}\right]^2\right\} \\
 &= \exp(-1.8) = \mathbf{16\%}
 \end{aligned}$$

Use I/I_{max} in place of e/e_{max} in eq. (15.20). As time increases, the last exponential becomes small relative to the first exponential, and can be neglected. Use eq. (15.20) without the last exponential and solve it for time:

$$\begin{aligned}
 t &= -\tau_1 \cdot \ln[(1/a) \cdot e / e_{max}] = -\tau_1 \cdot \ln[(1/a) \cdot I / I_{max}] \\
 &= -(70 \mu\text{s}) \cdot \ln[(1/1.014) \cdot 0.0833] = \mathbf{175. \mu\text{s}}
 \end{aligned}$$

Check: Agrees with Figs 15.25 & 15.26. Physics & units OK.

Exposition: The brief intense power surge can open circuit breakers, blow fuses, and melt electric power transformers. The resulting disruption of power distribution to businesses and homes can cause computers to malfunction, files to be lost, and peripherals to be destroyed.

INFO • The 30-30 Lightning Safety Rule

For the non-storm-chaser, use the 30-30 Rule of lightning safety: If you are outdoors and the time between the lightning flash and thunder is 30 s or less, then seek shelter immediately. Wait 30 minutes after hearing the last thunder clap before going outdoors.

When lightning strikes sandy ground, it can melt and fuse the sand along its path into a long narrow glassy tube called a **fulgurite**. When it strikes trees and flows down the trunk to the ground, it can cause the moisture and sap in the tree to instantly boil, causing the bark to splinter and explode outward as lethal wooden shrapnel. Sometimes the tree trunk will split, or the tree will ignite.

The electrons flowing in lightning all have a negative charge and try to repel each other. While moving along the narrow lightning channel, the electrons are constrained to be close together. However, if the lightning hits a metal-skinned airplane, the electrons push away from each other so as to flow along the outside surfaces of the airplane, thus protecting the people inside. Such a **Faraday cage** effect also applies to metal-skinned cars. Other than the surprisingly loud noise and bright lightning flash, you are well protected if you don't touch any metal. Where the lightning attaches to the car or aircraft, a pinhole can be burned through the metal.

Dangerous activities/locations associated with lightning strikes are:

1. Open fields including sports fields.
2. Boating, fishing, and swimming.
3. Using heavy farm or road equipment.
4. Playing golf.
5. Holding a hard-wired telephone.
6. Repairing or using electrical appliances.

You should take precautions to avoid being struck by lightning. Avoid water and metal objects. Get off of high ground. Avoid open fields. Stay away from solitary trees or poles or towers (which might attract lightning). Go indoors or inside a metal-skinned car, van or truck if lightning is within 10 km (i.e., 30 seconds or less between when you see a lightning flash and when you hear its thunder). Even if you don't see lightning or hear thunder, if the hair on your head, neck or arms stands on end, immediately go inside a building or car. If indoors, avoid using hard-wired phones, hair driers, or other appliances, and avoid touching metal plumbing or water in your sink, shower, or tub.

If you are outside and no shelter is available, crouch down immediately in the lowest possible spot with your feet together and your hands over your ears. Do not lie down, because once lightning strikes the ground or a tree, it often spreads out along the surface of the ground and can still hit you. To prevent lightning from going through your heart, do not put your hands on the ground.

If people near you are struck by lightning and fall down, do not assume they are dead. Lightning can cause a person to stop breathing or stop their heart, but they can often be revived. If a person isn't breathing, try performing mouth-to-mouth resuscitation.

tation. If a person has no pulse, and if you have the training, do cardiopulmonary resuscitation (CPR).

Cardiac arrest (stopped heart) is the main cause of death from a lightning strike. Surprisingly, there is usually very little burning of the skin. Other immediate effects include tinnitus (ringing in the ears due to the loud thunder), blindness, amnesia, confusion, cardiac arrhythmias, and vascular instability. Later problems include sleep disturbances, anxiety attacks, peripheral nerve damage, pain syndromes, fear of storms, personality changes, irritability, short-term memory difficulties, and depression. Lightning injures 800 to 1000 people per year in the USA, and kills 75 to 150 people per year. Support groups exist for lightning survivors.

15.3.6. Thunder

When lightning heats the air to $T = 15,000$ to $30,000$ K, it instantly increases the air pressure to $P = 1,000$ to $10,000$ kPa along the ionized lightning path, creating a **shock front** that moves at supersonic speeds up to ten times the speed of sound (i.e., $Ma = 10$, where Ma is **Mach number**). By $7 \mu\text{s}$ later, the supersonic shock-front speed has decreased to Mach 5, and has spread only about 1.5 cm from the edge of the lightning channel (Fig. 15.27). By 0.01 s after the lightning, the shock front has spread about 4 m in all directions around the lightning, and has a speed ($Ma = 1.008$) that is almost equal to the speed of sound ($Ma = 1$). Namely, it becomes a **sound wave** that continues to spread at the speed of sound, which you hear as thunder. So to understand thunder, we will study shock fronts first, and then sound.

15.3.6.1. Shock Front

A shock front in air is created by a pressure discontinuity or pressure step. The thickness of this pressure step is only a few micrometers. This shock front advances supersonically at speed C through the air toward the lower pressure. It is NOT like a piston that pushes against the ambient air in front of it. Instead it moves THROUGH the background low-pressure air, modifies the thermodynamic and dynamic state of the air molecules it overtakes, and leaves them behind as the front continues on. This modification of the air is irreversible, and causes entropy to increase.

To analyze the shock, picture an idealized vertical lightning channel (Fig. 15.28) of radius r_0 . Assume the background air is calm (relative to the speed of the shock) and of uniform thermodynamic state. For simplicity, assume that air is an ideal gas, which is a bad assumption for the temperatures and pressures inside the lightning channel.

Because the shock front will expand as a cylinder of radius r around the axis of the lightning channel,

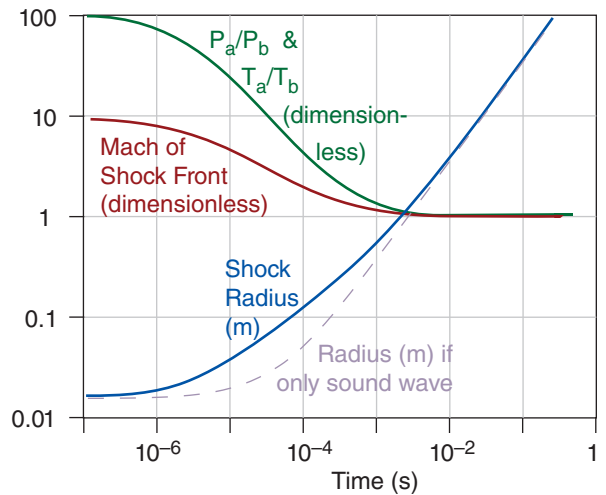

Figure 15.27

Evolution of initial stages of thunder as it propagates as a supersonic shock front. P_a/P_b is the ratio of average pressure behind the shock front to background pressure ahead of the front. T_a/T_b is similar ratio for absolute temperature. Propagation speed of the shock front is given by its Mach number. Radius from the lightning axis of the shock front and subsequent sound wave is compared to the radius if only a sound wave had been created without the initial supersonic shock wave.

INFO • Force of Thunder

One time when I was driving, lightning struck immediately next to my car. The shock wave instantly pushed the car into the next lane, without breaking any windows or causing damage. I was amazed at the power of the shock wave, and happy to be alive.
- R. Stull

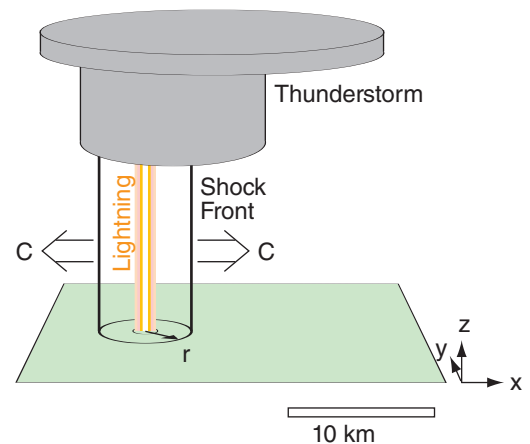

Figure 15.28

Sketch of idealized vertical lightning discharge that generates a cylindrical shock front of radius r that expands at speed C .

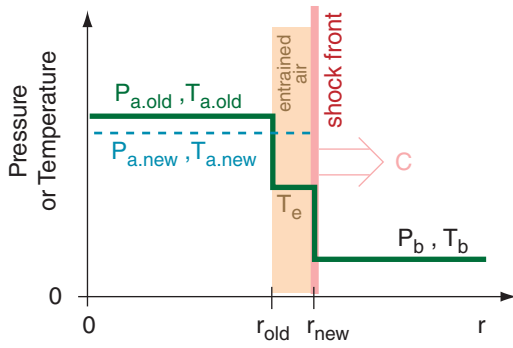

Figure 15.29

Characteristics of the thunder shock front as a function of radial distance r from the lightning-channel axis (at $r = 0$). P_a and T_a are the average pressure and temperature behind the shock front, relative to background conditions ahead of the front P_b and T_b . As the shock front overtakes background air molecules, their temperature is modified to be T_e , which is assumed to mix with the old conditions behind the front to create new average conditions. This distance ($r_{new} - r_{old}$) is a few μm .

ignore the vertical (because there is no net change in the vertical), and use the circular symmetry to treat this as a 1-D **normal-shock** problem in the horizontal. Namely, the movement of the shock front across the air molecules is perpendicular to the face of the shock front.

Use subscript b to indicate background air (not yet reached by the shock), and subscript e to indicate entrained air (namely, background air that has been modified by the shock-front passage). For simplicity, assume that the entrained air instantly mixes with the rest of the air inside the shock-front circle, and use subscript a to indicate the resulting average conditions inside that circle (Fig. 15.29).

For a normal-shock, the Mach number (dimensionless) of the shock wave expanding into the background air is

$$Ma = \left[\frac{(P_a / P_b) \cdot (k - 1) + k - 1}{2k} \right]^{1/2} \quad (15.21a)$$

where P is pressure, and $k = C_p / C_v$. For air, $k = 1.40$, allowing the previous equation to be simplified to:

$$Ma = \left[\frac{(P_a / P_b) \cdot 6 + 1}{7} \right]^{1/2} \quad (15.21b)$$

One equation for the speed of sound (s) in air is

$$s = (k \mathfrak{R} T)^{1/2} \quad (15.22)$$

where $\mathfrak{R} = C_p - C_v = 287 \text{ m}^2 \text{ s}^{-2} \text{ K}^{-1}$ is the gas constant, and T is absolute air temperature. For background air, this simplifies to

$$s_b = a_s \cdot (T_b)^{1/2} \quad (15.23)$$

where $a_s = 20 \text{ (m s}^{-1}\text{) K}^{-1/2}$ is a constant for air, and T_b is background air temperature (in Kelvin). For example, if the background air has temperature 27°C ($= 300 \text{ K}$), then the speed of sound is $s_b = 346.41 \text{ m s}^{-1}$.

By definition, the Mach number is the speed of the object (or the shock) divided by sound speed. Thus the speed C of the shock front through the calm background air is

$$C = Ma \cdot s_b \quad (15.24)$$

During a small time interval Δt , the radius r of the shock circle expands as:

$$r_{new} = r_{old} + C \cdot \Delta t \quad (15.25)$$

The thin layer of air immediately behind the shock front is warmed (due to compression) to:

$$T_e = T_b \cdot \frac{[2 + (k - 1) \cdot Ma^2][2k \cdot Ma^2 - k + 1]}{(k + 1)^2 Ma^2} \quad (15.26)$$

or

$$T_e = T_b \cdot \frac{[5 + Ma^2][7Ma^2 - 1]}{36Ma^2} \quad (15.27)$$

where T_b is background air temperature and Ma is the Mach number of the shock front. T_e is the temperature of the air entrained inside the shock circle.

By keeping track of the average temperature T_a of all air enclosed by the shock circle, you can use geometry to find how that average changes as the entrained air is added

$$T_{a,new} = T_e + \frac{(T_{a,old} - T_e)}{(r_{new} / r_{old})^2} \quad (15.28)$$

Lightning-formed shocks are quite different from shocks caused by chemical explosives (i.e., bombs). Conventional bombs explosively release large amounts of gas via chemical reactions, which increases the pressure, temperature, and density of the atmosphere by quickly adding gas molecules that were not there before. As the resulting shock front expands, there is a net out-rush of gas behind the shock as the gas density decreases toward background values.

Lightning, however, is a constant density (**isopycnal**) process, because no extra air molecules are added to the lightning channel. Namely, lightning starts with existing background air molecules and energizes whichever ones happen to be within the ionized channel. Furthermore, just outside the shock front nothing has changed in the background air (i.e., no density changes, and no movement of molecules toward or away from the shock front).

Therefore, by mass conservation, the average density ρ_a of air enclosed by the shock front is also constant and equal to the original (pre-lightning) background value ρ_b :

$$\rho_a = \rho_b = \text{constant} = P_b / \mathfrak{R} \cdot T_b \quad \bullet(15.29)$$

using the ideal gas law with P_b as background air pressure, and T_b as background air temperature (in Kelvin). Immediately behind the shock front, the entrained air has higher density and pressure, but this is compensated by lower-density lower-pressure air closer to the lightning axis, resulting in constant average density as shown above.

Finally, the average pressure P_a of all air enclosed by the shock circle is found using the ideal gas law with constant density:

$$P_a / P_b = T_a / T_b \quad \bullet(15.30)$$

where $T_a = T_{a.new}$. Equations (15.21) through (15.30) can be solved iteratively to find how conditions change as the shock evolves. Namely, P_a can be used back in eq. (15.21), and the calculations repeated. This assumes that the background thermodynamic state T_b and P_b of the undisturbed air is known.

To iterate, you need the initial conditions. Start with r_{old} = radius of the ionized lightning channel, although there is evidence that the incandescent region of air is about 10 to 20 times larger radius than this (so you could try starting with this larger value). Because of the isopycnal nature of lightning, if you know the initial lightning temperature T_a in Kelvin, you can use eq. (15.30) to find the initial pressure ratio P_a/P_b , as sketched in Fig. 15.30.

An iterative approach is demonstrated in a Sample Application, the results from which were used to create Fig. 15.27. The background air state was $T_b = 300\text{K}$ and $P_b = 100 \text{ kPa}$, giving $\rho_b = 1.1614 \text{ kg m}^{-3}$. For the lightning, I used initial conditions of $r_{old} = 1.5 \text{ cm} = 0.015 \text{ m}$, $T_{a.old} = 30,000 \text{ K}$, $P_a = 10,000 \text{ kPa}$.

Anyone who has been very close (within 1 m or less) of a lightning strike (but not actually hit by the lightning itself) feels a tremendous force that can instantly throw your body (or your car if you are driving) many meters horizontally (as well as rupturing your ear drums). This is the combined effect of the pressure difference across the shock front as it passes your body or your car, and the dynamic effect of a supersonic wind in the thin layer of entrained air immediately behind the shock front.

Assuming a normal shock, the extremely brief, outward-directed wind M_e in the entrained air immediately behind the shock is:

$$M_e = C - [C^2 - 2 \cdot C_p \cdot (T_e - T_b)]^{1/2} \quad (15.31)$$

Sample Application

Background atmospheric conditions are $P_b = 100 \text{ kPa}$, $T_b = 300 \text{ K}$, and calm winds. If lightning heats the air in the lightning channel to 15,000 K, what is the initial speed of the shock front, and the initial speed of the air behind the shock front?

Find the Answer

Given: $P_b = 100 \text{ kPa}$, $T_b = 300 \text{ K}$, $M_b = 0 \text{ m s}^{-1}$.

$T_a = 15,000 \text{ K}$

Find: $C = ? \text{ m s}^{-1}$, $M_e = ? \text{ m s}^{-1}$

The shock speed equation requires the Mach speed and the speed of sound, which must be calculated first. Mach speed, in turn, depends on the initial pressure ratio. Use eq. (15.30) to find the pressure ratio:

$$P_a/P_b = T_a/T_b = (15000 \text{ K})/(300 \text{ K}) = 50$$

Next, use eq (15.21) to find the Mach speed of the shock front through the background air:

$$Ma = \{[(50) \cdot 6 + 1] / 7\}^{1/2} = 6.56$$

The background speed of sound from eq. (15.23) is:

$$s_b = [20 (\text{m s}^{-1}) \cdot \text{K}^{-1/2}] \cdot (300 \text{ K})^{1/2} = 346.4 \text{ m s}^{-1}$$

Thus, using eq. (15.24):

$$C = 6.56 \cdot (346.4 \text{ m s}^{-1}) = \underline{2,271.6 \text{ m s}^{-1}}$$

The equation for wind speed behind the shock requires the temperature behind the shock. Use eq. (15.27):

$$T_e = (300 \text{ K}) \cdot \{ [5 + 6.56^2] \cdot [7 \cdot 6.56^2 - 1] / (36 \cdot 6.56^2) \} \\ = (300 \text{ K}) \cdot \{ 48 \cdot 300 / 1548 \} = 2791 \text{ K}$$

Finally, using eq. (15.31):

$$M_e = (2,271.6 \text{ m s}^{-1}) - [(2,271.6 \text{ m s}^{-1})^2 - 2 \cdot (1005 \text{ m}^2 \text{ s}^{-2} \text{ K}^{-1}) \cdot (2791 \text{ K} - 300 \text{ K})]^{1/2} \\ = 2,271.6 - 392.3 \text{ m s}^{-1} = \underline{1,879.3 \text{ m s}^{-1}}$$

Check: Units OK. Physics OK.

Exposition: Both the initial shock front and the initial wind behind the shock are supersonic, but the wind is slower than the shock front.

Nonetheless, the initial shock-front speed (about $2.3 \times 10^3 \text{ m s}^{-1}$) is still much slower than the speed of light ($3 \times 10^8 \text{ m s}^{-1}$). Hence, we will see the lightning before we hear the thunder (except if lightning strikes you).

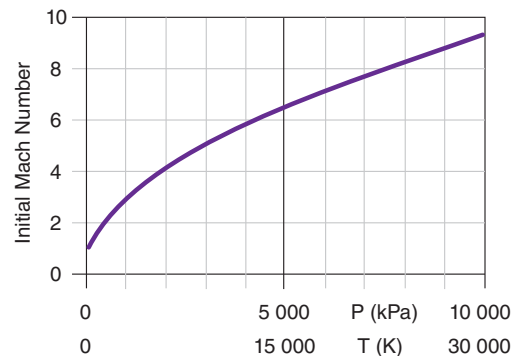

Figure 15.30
Higher temperature T in the lightning channel creates higher pressure P , which generates a shock front that initially moves with greater Mach number. (Mach 1 is the speed of sound).

Sample Application (S)

Background air is calm, with temperature 300 K and pressure 100 kPa. If lightning heats the air to 30,000 K within a vertical lightning channel of radius 1.5 cm, then find and plot the evolution of average temperature inside the shock circle (relative to background temperature), average relative pressure, Mach of the shock front, and shock radius. (Namely, produce the data that was plotted in Fig. 15.27.)

Find the Answer

Given: $P_b = 100 \text{ kPa}$, $T_b = 300 \text{ K}$, $M_b = 0 \text{ m s}^{-1}$.

$T_a = 30,000 \text{ K}$ initially

Find: $T_a/T_b = ?$, $P_a/P_b = ?$, $Ma = ?$, $r = ? \text{ m}$ and how they vary with time.

This is easily done with a spreadsheet. Because conditions vary extremely rapidly initially, and vary slower later, I will not use a constant time step for the iterations. Instead, I will use a constant ratio of

$$r_{new}/r_{old} = 1.05 \tag{a}$$

Namely, I will redo the calculation for every 5% increase in shock radius. Thus,

$$t_{new} = t_{old} + (r_{new} - r_{old})/C_{old} \tag{b}$$

Procedure: First, enter the given background air values in cells on the spreadsheet, and compute the speed of sound in the background air.

Next, create a table in the spreadsheet that holds the following columns: r , t , T_a , P_a/P_b , Ma , C , and T_e .

In the first row, start with $r_{old} = 0.015 \text{ m}$ at $t_{old} = 0$, and initialize with $T_a = 30,000 \text{ K}$. Then compute the ratio T_a/T_b , and use that ratio in eq. (15.30) to find P_a/P_b . Use this pressure ratio to find Ma (using eq. 15.21) and C (using eq. 15.24 and knowing background sound speed). Finally, the last column in the first row is T_e found using eq. (15.27).

The second row is similar to the first, except estimate the new r using eq. (a), and the new t using eq. (b). The new T_a can be found using eq. (15.28). The other columns can then be filled down into this second row. Finally, the whole second row can be filled down to as many rows as you want (be careful: do not complete the table by filling down from the first row). Some results from that spreadsheet are shown in the table in the next column.

Fig. 15.27 shows a plot of these results.

Check: Units OK. Physics OK. Some decimal places have been dropped to fit in the table on this page.

Exposition: To check for accuracy, I repeated these calculations using smaller steps (1% increase in shock radius), and found essentially the same answer.

The equations in this section for shock-front propagation are not exact. My assumption of constant density, while correct when averaged over large scales, is probably not correct at the very small scale at the shock front. Thus, my equations are an oversimplification.

(table is in next column)

where $C_p = 1005 \text{ m}^2 \text{ s}^{-2} \text{ K}^{-1}$ is the specific heat of air at constant pressure. Although initially very fast, these winds are slower than the speed of the shock front. Initial supersonic post-shock winds are about 2500 m s^{-1} while the shock radius is still small (1.5 cm), but they quickly diminish to subsonic values of about 10 m s^{-1} as the shock front expands past 2 m radius.

The resulting sequence of winds at any point not on the lightning axis is: (1) no lightning-created winds prior to shock front passage; (2) near instantaneous increase in outward-directed winds M_e immediately after the shock front passes; which is quickly followed by (3) weaker inward-directed winds (never supersonic) drawn back toward the lower pressure along the lightning axis in order to conserve mass. A similar sequence of events has been observed with shock fronts from atmospheric nuclear-bomb explosions just above ground.

Sample Application (continuation)

r (m)	t (s)	T _a (K)	P _a /P _b	Ma	C (m s ⁻¹)	T _e (K)
0.0150	0	30000	100.0	9.27	3210	5291
0.0158	2.34E-07	27703	92.3	8.90	3085	4908
0.0165	4.89E-07	25584	85.3	8.56	2965	4555
0.0174	7.68E-07	23629	78.8	8.23	2849	4229
0.0182	1.07E-06	21825	72.7	7.91	2739	3928
0.0191	1.41E-06	20161	67.2	7.60	2632	3651
0.0201	1.77E-06	18626	62.1	7.30	2530	3395
0.0211	2.17E-06	17210	57.4	7.02	2433	3159
0.0222	2.60E-06	15904	53.0	6.75	2339	2941
0.0233	3.07E-06	14699	49.0	6.49	2249	2740
0.0244	3.59E-06	13587	45.3	6.24	2162	2555
0.0257	4.16E-06	12561	41.9	6.00	2079	2384
0.0269	4.77E-06	11615	38.7	5.77	2000	2226
0.0283	5.45E-06	10742	35.8	5.55	1924	2081
0.0297	6.18E-06	9937	33.1	5.34	1850	1946
0.0312	6.98E-06	9194	30.6	5.14	1780	1822
•••						
0.0958	6.73E-05	1729	5.8	2.25	781	572
0.1006	7.35E-05	1621	5.4	2.19	757	553
0.1056	8.01E-05	1522	5.1	2.12	734	536
0.1109	8.73E-05	1430	4.8	2.06	712	520
0.1164	9.51E-05	1346	4.5	2.00	692	506
0.1222	1.03E-04	1268	4.2	1.94	672	492
•••						
3.5424	0.0094	307	1.02	1.01	350	302
3.7195	0.0099	306	1.02	1.01	350	302
3.9055	0.0105	306	1.02	1.01	349	302
4.1007	0.0110	306	1.02	1.01	349	302
4.3058	0.0116	305	1.02	1.01	349	301
4.5210	0.0122	305	1.02	1.01	349	301
•••						
35.091	0.100	300	1.00	1.00	347	300
36.845	0.105	300	1.00	1.00	347	300
38.687	0.111	300	1.00	1.00	347	300
•••						

15.3.6.2. Sound

By about 0.1 s after the lightning stroke, the shock wave has radius 35 m, and has almost completely slowed into a sound wave. Because this happens so quickly, and so close to the lightning channel, ignore the initial shock aspects of thunder in this subsection, and for simplicity assume that the sound waves are coming directly from the lightning channel.

The speed of sound relative to the air depends on air temperature T — sound travels faster in warmer air. But if the air also moves at wind speed M , then the total speed of sound s relative to the ground is

$$s = s_0 \cdot \left(\frac{T}{T_0}\right)^{1/2} + M \cdot \cos(\phi) \quad \bullet(15.32)$$

where $s_0 = 343.15 \text{ m s}^{-1}$ is a reference sound speed at $T_0 = 293 \text{ K}$ (i.e., at 20°C), and ϕ is the angle between the direction of the sound and the direction of the wind. Namely, a head-wind causes slower propagation of sound waves.

Because light travels much faster than sound, you can estimate the range to a lightning stroke by timing the interval Δt between when you see lightning and hear thunder. Because sound travels roughly $1/3 \text{ km/s}$, divide the time interval in seconds by 3 to estimate the range in km. For range in statute miles, divide the time interval by 5 instead. These approximations are crude but useful.

Because sound wave speed depends on temperature, the portion of a wave front in warmer air will move faster than the portion in cooler air. This causes the wave front to change its direction of advance. Thus, its propagation path (called a **ray path**) will bend (**refract**).

Consider horizontal layers of the atmosphere having different temperatures T_1 and T_2 . If a sound wave is moving through layer one at elevation angle α_1 , then after passing into layer two the new ray elevation angle will be α_2 .

To quantify this effect, define an **index of refraction** for sound in calm air as:

$$n = \sqrt{T_0 / T} \quad (15.33)$$

where the reference temperature is $T_0 = 293 \text{ K}$. **Snell's law** states that

$$n \cdot \cos(\alpha) = \text{constant} \quad (15.34)$$

When applied to a sound ray moving from one layer to another, Snell's law can be rewritten as:

$$\cos(\alpha_2) = \sqrt{T_2 / T_1} \cdot \cos(\alpha_1) \quad \bullet(15.35)$$

See the Atmospheric Optics chapter for more info.

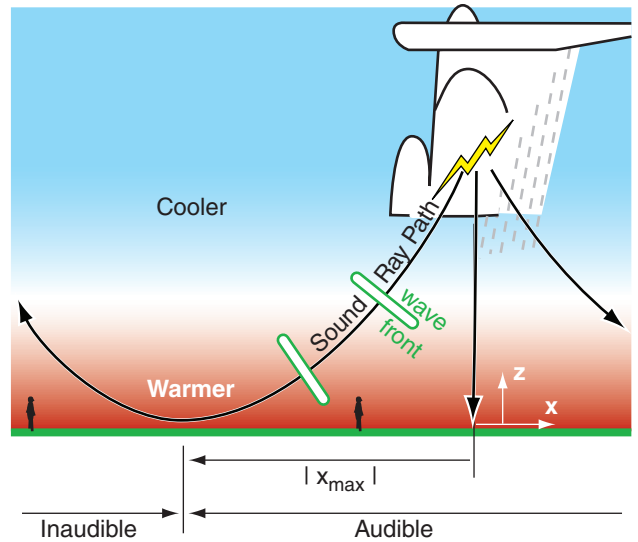

Figure 15.31 Wave fronts, ray paths, and audible range of thunder.

Sample Application

You see a thunderstorm approaching from the southwest. It is warm out ($T = 35^\circ\text{C}$). Facing toward the storm, you see a lightning flash and hear the thunder 12 s later, and you feel a 10 m s^{-1} wind on your back. What is the distance to the lightning stroke?

Find the Answer

Given: With the wind at your back, this means that the wind blowing opposite to the direction that sound must travel to reach you; hence, $\phi = 180^\circ$. Also, $\Delta t = 12 \text{ s}$, $T = 35^\circ\text{C} = 308 \text{ K}$, $M = 10 \text{ m s}^{-1}$. Find: $\Delta x = ? \text{ km}$

Light speed is so fast that it is effectively instantaneous. So the time interval between “flash” and “bang” depends on sound speed:

Use eq. (15.32):

$$s = (343.15 \text{ m s}^{-1}) \cdot [308\text{K}/293\text{K}]^{1/2} + (10 \text{ m s}^{-1}) \cdot \cos(180^\circ) = 351.8 - 10.0 = 341.8 \text{ m s}^{-1}$$

But speed is distance per time ($s = \Delta x / \Delta t$). Rearrange: $\Delta x = s \cdot \Delta t = (341.8 \text{ m s}^{-1}) \cdot (12 \text{ s}) = \underline{4.102 \text{ km}}$

Check: Physics and units OK.

Exposition: Typical wind speeds are much smaller than the speed of sound; hence, the distance calculation is only slightly affected by wind speed.

The approximate method of dividing the time interval by 3 is sometimes called the **3 second rule**. This rule is simple enough to do in your head while watching the storm, and would have allowed you to estimate $\Delta x \approx (12 \text{ s}) / (3 \text{ s km}^{-1}) = 4 \text{ km}$. Close enough.

If the time interval is 30 s or less, this means the storm is 10 km or closer to you, so you should immediately seek shelter. See the lighting safety INFO boxes.

Sample Application (S)

Suppose lightning occurs at 4 km altitude in a thunderstorm. Assume $\Delta T/\Delta z = -8 \text{ K/km} = \text{constant}$. (a) How far horizontally from the lightning can you hear the thunder? (b) For the ray path that is tangent to the ground at that x_{max} point, plot the ray path backwards up to the lightning. $T = 308 \text{ K}$ near the ground.

Find the Answer

Given: $z = 4 \text{ km}$, $T = 308 \text{ K}$, $\gamma = 8 \text{ K km}^{-1}$
 Find: $x_{max} = ? \text{ km}$, and plot (x, z) from $z = 0$ to 4 km

Use eq. (15.38): $x_{max} = 2 \cdot [(308 \text{ K}) \cdot (4 \text{ km}) / (8 \text{ K km}^{-1})]^{1/2} = \mathbf{24.8 \text{ km}}$

Pick a small $\Delta x = 0.5 \text{ km}$, and use eq. (15.36):
 $\Delta\alpha = (8 \text{ K km}^{-1}) \cdot (0.5 \text{ km}) / [2 \cdot (308 \text{ K})] = 0.00649 \text{ radians}$

Use a spreadsheet to solve eqs. (15.37) with the constant value of $\Delta\alpha$ calculated above. We know the sound ray is tangent to the ground ($\alpha = 0 \text{ radians}$) at the inaudibility point. Define $x = 0 \text{ km}$ and $z = 0 \text{ km}$ at this starting point. Then iterate eqs. (15.37) up to the altitude of the lightning.

x (km)	α (rad)	Δz (km)	z (km)
0	0	0	0
0.5	0.00649	0.00325	0.00325
1.0	0.01299	0.00649	0.00974
1.5	0.01948	0.00974	0.0195
2.0	0.02597	0.01299	0.03247
...
24.5	0.31818	0.16469	4.0477

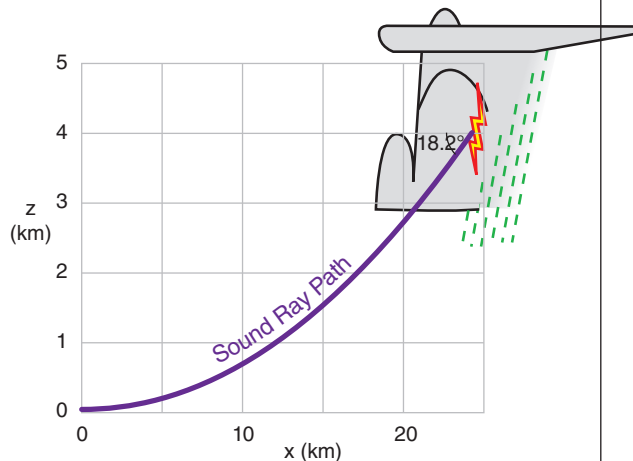

Check: Physics and units OK.

Exposition: $x = 0$ in the graph above is distance x_{max} from the lightning, where x_{max} was well approximated by eq. (15.38). For these weather conditions, of all the sound rays that radiated outward from the lightning origin, the one that became tangent to the ground was the one that left the storm with elevation angle $18.2^\circ (= 0.31818 \text{ radians})$ downward from horizontal.

The previous expressions for Snell’s law assumed a finite step change in temperature between layers that caused a sharp kink in the ray path. But if there is a gradual temperature change with distance along the ray path, then Snell’s law for calm winds says there is a gradual bending of the ray path:

$$\Delta\alpha = \frac{\gamma}{2 \cdot T} \cdot \Delta x \tag{15.36}$$

where $\Delta\alpha$ is a small incremental change in ray elevation angle (radians) for each small increment of horizontal distance Δx traveled by the light. The vertical temperature variation is expressed as a lapse rate $\gamma = -\Delta T/\Delta z$, where T is the absolute temperature of background air. As a case study, we can assume γ is constant with height, for which case the ratio in eq. (15.36) is also nearly constant because T typically varies by only a small fraction of its magnitude.

You can solve eq (15.36) iteratively. Start with a known ray angle α at a known (x, z) location, and set a small fixed Δx value for your horizontal increment. Then, solve the following equations sequentially:

$$\begin{aligned} x_{new} &= x_{old} + \Delta x \\ \alpha_{new} &= \alpha_{old} + \Delta\alpha \\ \Delta z &= \Delta x \cdot \tan(\alpha) \\ z_{new} &= z_{old} + \Delta z \end{aligned} \tag{15.37}$$

Continue solving eqs. (15.36 & 15.37) for more steps of Δx , using the “new” values output from the previous step as the “old” values to input for the next step. Save all the x_{new} and z_{new} values, because you can plot these to see the curved ray path (Fig. 15.31).

Thunderstorms usually happen on days when the sun has heated the ground, which in turn heated the bottom of the atmosphere. Thus, temperature often decreases with increasing height on thunderstorm days. Since sound waves bend toward air that is cooler, it means the thunder ray paths tend to be concave up (Fig 15.31).

This curvature can be significant enough that there is a max distance x_{max} beyond which you cannot hear thunder (i.e., it is inaudible):

$$x_{max} \cong 2 \cdot \sqrt{T \cdot z / \gamma} \tag{15.38}$$

where the sound has originated at height z , calm winds were assumed, and T is in Kelvins.

With wind, Snell’s equation for the ray path is:

$$\begin{aligned} & \frac{n \cdot (\cos \alpha) \left[1 - (Ma \cdot n \cdot \sin \alpha)^2 \right] - Ma \cdot (n \cdot \sin \alpha)^2}{1 + Ma \cdot n \cdot (\cos \alpha) \left[1 - (Ma \cdot n \cdot \sin \alpha)^2 \right]^{1/2} - (Ma \cdot n \cdot \sin \alpha)^2} \\ & = \text{constant} \end{aligned} \tag{15.39}$$

where $Ma = M/s_0$ is the Mach number of the wind.

15.4. TORNADOES

Tornadoes are violently rotating, small-diameter columns of air in contact with the ground. Diameters range from 10 to 1000 m, with an average of about 100 m. In the center of the tornado is very low pressure (order of 10 kPa lower than ambient).

Tornadoes are usually formed by thunderstorms, but most thunderstorms do not spawn tornadoes. The strongest tornadoes come from supercell thunderstorms. Tornadoes have been observed with a wide variety of shapes (Fig. 15.32).

15.4.1. Tangential Velocity & Tornado Intensity

Tangential velocities around tornadoes range from about 18 m s⁻¹ for weak tornadoes to greater than 140 m s⁻¹ for exceptionally strong ones. Tornado rotation is often strongest just above the ground (15 to 150 m AGL), where upward vertical velocities of 25 to 60 m s⁻¹ have been observed in the outer wall of the tornado. This combination of updraft and rotation can rip trees, animals and buildings from the ground and destroy them. It can also loft trucks, cars, and other large and small objects, which can fall outside the tornado path causing more damage.

Often a two-region model is used to approximate tangential velocity M_{tan} in a tornado, with an internal **core** region of radius R_o surrounded by an external region. R_o corresponds to the location of fastest tangential velocity $M_{tan\ max}$ (Fig. 15.33), which is sometimes assumed to coincide with the outside edge of the visible funnel. Air in the core of the tornado rotates as a solid-body, while air outside the core is irrotational (has no relative vorticity as it moves around the tornado axis), and conserves angular momentum as it is drawn into the tornado. This model is called a **Rankine combined vortex (RCV)**.

The pressure deficit is $\Delta P = P_\infty - P$, where P is the pressure at any radius R from the tornado axis, and P_∞ is ambient pressure far away from the tornado (for $P_\infty \geq P$). At R_o , the inner (core) and outer tangential wind speeds match, and the inner and outer pressure deficits match. Thus:

Core Region ($R < R_o$):

$$\frac{M_{tan}}{M_{tan\ max}} = \frac{R}{R_o} \quad \bullet(15.40)$$

$$\frac{\Delta P}{\Delta P_{max}} = 1 - \frac{1}{2} \left(\frac{R}{R_o} \right)^2 \quad \bullet(15.41)$$

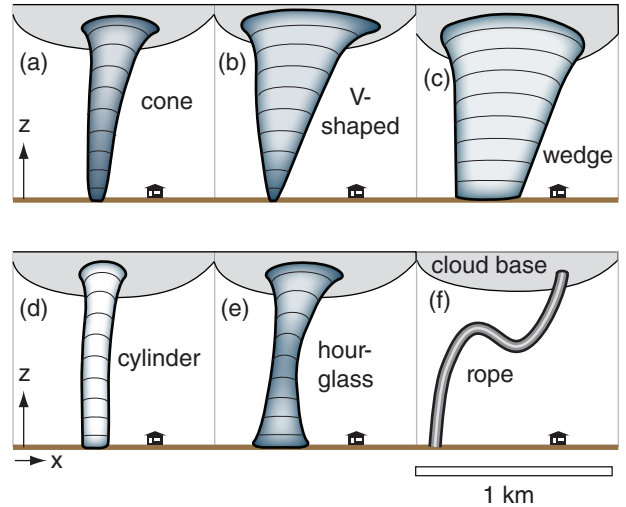

Figure 15.32
Illustration of some of the different tornado shapes observed.

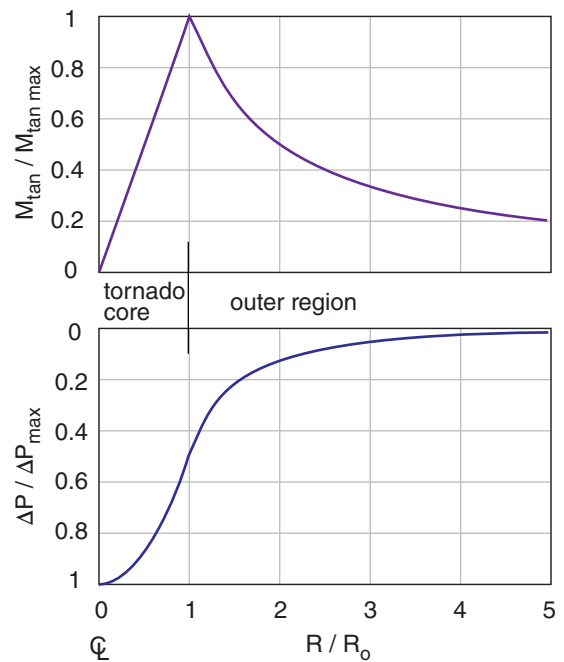

Figure 15.33
A Rankine-combined-vortex (RCV) model for tornado tangential velocity and pressure. The pressure deficit is plotted with reversed ordinate, indicating lower pressure in the tornado core.

Sample Application

If the max pressure deficit in the center of a 20 m radius tornado is 10 kPa, find the max tangential wind speed, and the wind and pressure deficit at $R = 50$ m.

Find the Answer

Given: $R_o = 20$ m, $\Delta P_{max} = 10$ kPa, $R = 50$ m

Find: $M_{tan\ max} = ?$ m s⁻¹.

Also $M_{tan} = ?$ m s⁻¹ and $\Delta P = ?$ kPa at $R = 50$ m.

Assume: $\rho = 1$ kg m⁻³.

Use eq. (15.44):

$$M_{tan\ max} = [\Delta P_{max} / \rho]^{1/2} = [(10,000 \text{ Pa}) / (1 \text{ kg m}^{-3})]^{1/2} = \mathbf{100 \text{ m s}^{-1}}$$

Because $R > R_o$, use outer-region eqs. (15.42 & 15.43):

$$M_{tan} = (100 \text{ m s}^{-1}) \cdot [(20 \text{ m}) / (50 \text{ m})] = \mathbf{40 \text{ m s}^{-1}}$$

$$\Delta P = 0.5 \cdot (10 \text{ kPa}) \cdot [(20 \text{ m}) / (50 \text{ m})]^2 = \mathbf{0.8 \text{ kPa}}$$

Check: Physics OK. Units OK. Agrees with Fig. 15.33.

Exposition: 10 kPa is quite a large pressure deficit in the core — roughly 10% of sea-level pressure. However, most tornadoes are not this violent. Typical tangential winds of 60 m s⁻¹ or less would correspond to core pressure deficits of 3.6 kPa or less.

Outer Region ($R > R_o$):

$$\frac{M_{tan}}{M_{tan\ max}} = \frac{R_o}{R} \quad \bullet(15.42)$$

$$\frac{\Delta P}{\Delta P_{max}} = \frac{1}{2} \left(\frac{R_o}{R} \right)^2 \quad \bullet(15.43)$$

These equations are plotted in Fig. 15.33, and represent the wind relative to that in the center of the tornado.

Max tangential velocity (at $R = R_o$) and max **core pressure deficit** (ΔP_{max} , at $R = 0$) are related by

$$\Delta P_{max} = \rho \cdot (M_{tan\ max})^2 \quad \bullet(15.44)$$

where ρ is air density. This equation was derived from the **Bernoulli equation**. $M_{tan\ max}$ can also be described as a **cyclostrophic wind** as explained in the Forces & Winds chapter (namely, it is a balance between centrifugal and pressure-gradient forces). Forecasting these maximum values is difficult.

Near the Earth's surface, frictional drag near the ground slows the air below the cyclostrophic speed. Thus there is insufficient centrifugal force to balance pressure-gradient force, which allows air to be sucked into the bottom of the tornado. Further away from the ground, the balance of forces causes zero net radial flow across the tornado walls; hence, the tornado behaves similar to a vacuum-cleaner hose.

The previous 5 equations gave tangential wind speed relative to the center of the tornado. But the tornado also moves horizontally (**translates**) with its parent thunderstorm. The total wind M_{total} at any point near the tornado is the vector sum of the rotational wind M_{tan} plus the translational wind M_{tr} (Fig. 15.34). The max wind speed M_{max} associated with the tornado is

$$|M_{max}| = |M_{tan\ max}| + |M_{tr}| \quad \bullet(15.45)$$

and is found on the right side of the storm (relative to its translation direction) for cyclonically (counterclockwise, in the Northern Hemisphere) rotating tornadoes.

Most tornadoes rotate cyclonically. Less than 2% of tornadoes rotate the opposite direction (anticyclonically). This low percentage is due to two factors: (1) Coriolis force favors mesocyclones that rotate cyclonically, and (2) friction at the ground causes a turning of the wind with increasing height (Fig. 15.42, presented in a later section), which favors right-moving supercells in the Northern Hemisphere with cyclonically rotating tornadoes.

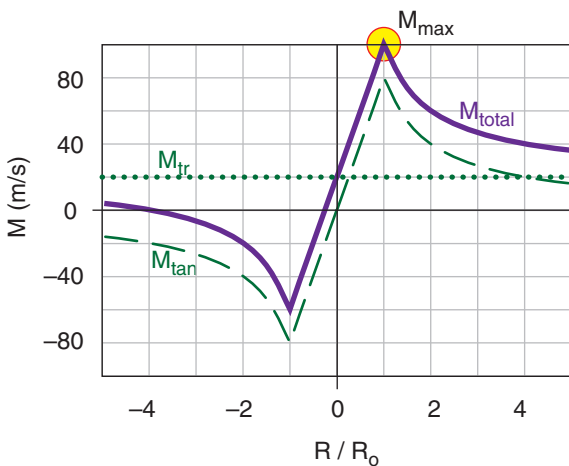

Figure 15.34
Illustration of sum of relative rotational (M_{tan}) wind and tornado translation (M_{tr}) to yield total winds (M_{total}) measured at the ground. Tornado intensity is classified based on the maximum wind speed (M_{max}) anywhere in the tornado.

One **tornado damage scale** was devised by the Tornado and Storm Research Organization in Europe, and is called the **TORRO scale (T)**. Another scale was developed for North America by Ted Fujita, and is called the **Fujita scale (F)**.

In 2007 the Fujita scale was revised into an **Enhanced Fujita (EF)** scale (Table 15-3), based on better measurements of the relationship between winds and damage for 28 different types of structures. It is important to note that the EF intensity determination for any tornado is based on a damage survey AFTER the tornado has happened.

For example, consider modern, well-built single-family homes and duplexes, typically built with wood or steel studs, with plywood roof and outside walls, all covered with usual types of roofing, sidings, or brick. For this structure, use the following damage descriptions to estimate the EF value:

- If near the threshold of visible damage, then EF0 or less.
- If loss of gutters, or awnings, or vinyl or metal siding, or less than 20% of roof covering material, then EF0 - EF1.
- If broken glass in doors and windows, or roof lifted up, or more than 20% of roof covering miss-

ing, or chimney collapse, or garage doors collapse inward, or failure of porch or carport, then EF0 - EF2.

- If entire house shifts off foundation, or large sections of roof structure removed (but most walls remain standing), then EF1 - EF3.
- If exterior walls collapse, then EF2 - EF3.
- If most walls collapse, except small interior rooms, then EF2 - EF4.
- If all walls collapse, then EF3 - EF4.
- If total destruction & floor slabs swept clean, then EF4 - EF5.

Similar damage descriptions for the other 27 types of structures (including trees) are available from the USA Storm Prediction Center.

For any EF value (such as EF = 4), the lower threshold of maximum tangential 3-second-gust wind speed M_{max} is approximately:

$$M_{max} = M_o + a \cdot (EF)^{1.2} \tag{15.46}$$

where $M_o = 29.1 \text{ m s}^{-1}$ and $a = 8.75 \text{ m s}^{-1}$.

The “derived” gust thresholds listed in Table 15-3 are often converted to speed units familiar to the public and then rounded to pleasing integers of

Table 15-3. Enhanced Fujita scale for tornado-damage intensity. (Derived-scale speeds from NOAA Storm Prediction Center.)

Scale	Derived Max Tangential 3 s Gust Speed (m/s)	Operational Scales		Damage Classification Description (from the old Fujita F scale)	Relative Frequency	
		EF Scale (stat. miles/h)	Old F Scale (km/h)		USA	Canada
EF0	29.1 – 38.3	65 – 85	64 – 116	Light damage; some damage to chimneys, TV antennas; breaks twigs off trees; pushes over shallow-rooted trees.	29%	45%
EF1	38.4 – 49.1	86 – 110	117 – 180	Moderate damage; peels surface off roofs; windows broken; light trailer homes pushed or turned over; some trees uprooted or snapped; moving cars pushed off road.	40%	29%
EF2	49.2 – 61.6	111 – 135	181 – 252	Considerable damage; roofs torn off wood-frame houses leaving strong upright walls; weak buildings in rural areas demolished; mobile homes destroyed; large trees snapped or uprooted; railroad boxcars pushed over; light object missiles generated; cars blown off roads.	24%	21%
EF3	61.7 – 75.0	136 – 165	253 – 330	Severe damage; roofs and some walls torn off wood-frame houses; some rural buildings completely destroyed; trains overturned; steel-framed hangars or warehouse-type structures torn; cars lifted off of the ground; most trees in a forest uprooted or snapped and leveled.	6%	4%
EF4	75.1 – 89.3	166 – 200	331 – 417	Devastating damage; whole wood-frame houses leveled leaving piles of debris; steel structures badly damaged; trees debarked by small flying debris; cars and trains thrown or rolled considerable distances; large wind-blown missiles generated.	2%	1%
EF5	≥ 89.4	> 200	418 – 509	Incredible damage; whole wood-frame houses tossed off foundation and blown downwind; steel-reinforced concrete structures badly damaged; automobile-sized missiles generated; incredible phenomena can occur.	< 1%	0.1%

Sample Application
 Find Enhanced Fujita & TORRO intensities for $M_{max} = 100 \text{ m s}^{-1}$.

Find the Answer
 Given: $M_{max} = 100 \text{ m s}^{-1}$.
 Find: EF and T intensities

Use Tables 15-3 and 15-4: \approx **EF5** , **T8** .

Exposition: This is a violent, very destructive, significant tornado.

nearly the correct value. Such a result is known as an **Operational Scale** (see Table 15-3).

Tornado intensity varies during the life-cycle of the tornado, so different levels of destruction are usually found along the damage path for any one tornado. Tornadoes of strength EF2 or greater are labeled **significant tornadoes**.

The TORRO scale (Table 15-4) is defined by maximum wind speed M_{max} but in practice is estimated by damage surveys. The lower threshold of wind-speed for any **T** value (e.g., T7) is defined approximately by:

$$M_{max} \approx a \cdot (T + 4)^{1.5} \tag{15.47}$$

where $a = 2.365 \text{ m s}^{-1}$ and **T** is the TORRO tornado intensity value. A weak tornado would be classified as T0, while an extremely strong one would be T10 or higher.

Any tornado-damage scale is difficult to use and interpret, because there are no actual wind measurements for most events. However, the accumulation of tornado-damage-scale estimates provides valuable statistics over the long term, as individual errors are averaged out.

Table 15-4. TORRO tornado scale. (from www.torro.org.uk/site/tscale.php)

Scale	Max. Speed (m s ⁻¹)	Tornado Intensity & Damage Description (Abridged from the Torro web site) [UK “articulated lorry” ≈ USA “semi-trailer truck” or “semi”]
T0	17 – 24	Light. Loose light litter raised from ground in spirals; tents, marquees disturbed; exposed tiles & slates on roofs dislodged; twigs snapped; visible damage path through crops.
T1	25 – 32	Mild. Deck chairs, small plants, heavy litter airborne; dislodging of roof tiles, slates, and chimney pots; wooden fences flattened; slight damage to hedges and trees.
T2	33 – 41	Moderate. Heavy mobile homes displaced; semis blown over; garden sheds destroyed; garage roofs torn away; damage to tile and slate roofs and chimney pots; large tree branches snapped; windows broken.
T3	42 – 51	Strong. Mobile homes overturned & badly damaged; light semis destroyed; garages and weak outbuildings destroyed; much of the roofing material removed; some larger trees uprooted or snapped.
T4	52 – 61	Severe. Cars lifted; mobile homes airborne & destroyed; sheds airborne for considerable distances; entire roofs removed; gable ends torn away; numerous trees uprooted or snapped.
T5	62 – 72	Intense. Heavy motor vehicles lifted (e.g., 4 tonne trucks); more house damage than T4; weak buildings completely collapsed; utility poles snapped.
T6	73 – 83	Moderately Devastating. Strongly built houses lose entire roofs and perhaps a wall; weaker built structures collapse completely; electric-power transmission pylons destroyed; objects embedded in walls.
T7	84 – 95	Strongly Devastating. Wooden-frame houses wholly demolished; some walls of stone or brick houses collapsed; steel-framed warehouse constructions buckled slightly; locomotives tipped over; noticeable debarking of trees by flying debris.
T8	96 – 107	Severely Devastating. Cars hurled great distances; wooden-framed houses destroyed and contents dispersed over large distances; stone and brick houses irreparably damaged; steel-framed buildings buckled.
T9	108 – 120	Intensely Devastating. Many steel-framed buildings badly demolished; locomotives or trains hurled some distances; complete debarking of standing tree trunks.
T10	121 – 134	Super. Entire frame houses lifted from foundations, carried some distances & destroyed; severe damage to steel-reinforced concrete buildings; damage track left with nothing standing above ground.

15.4.2. Appearance

Two phenomena can make tornadoes visible: water droplets and debris (Fig. 15.35). Sometimes these processes make only the bottom or top part of the tornado visible; rarely, the whole tornado is invisible. Regardless of whether you can see the tornado, if the structure consists of a violently rotating column of air, then it is classified as a tornado.

Debris can be formed as the tornado destroys things on the Earth’s surface. The resulting smaller fragments (dirt, leaves, grass, pieces of wood, bugs, building materials and papers from houses and barns) are drawn into the tornado wall and upward, creating a visible **debris cloud**. (Larger items such as whole cars can be lifted by the more intense tornadoes and tossed outward, some as much as 30 m.) If tornadoes move over dry ground, the debris cloud can include dust and sand. Debris clouds form at the ground, and can extend to various heights for different tornadoes, including some that extend up to wall-cloud base.

The water-condensation funnel is caused by low pressure inside the tornado, which allows air to expand as it is sucked horizontally toward the core. As the air expands it cools, and can reach saturation if the pressure is low enough and the initial humidity of the air is great enough. The resulting cloud of water droplets is called a **funnel cloud**, and usually extends downward from the thunderstorm cloud base. Sometimes this condensation funnel cloud can reach all the way to the ground. Most strong tornadoes have both a condensation funnel and a debris cloud (Fig. 15.35).

Because the tornado condensation funnel is formed by a process similar to the lifting condensation level (LCL) for normal convective cloud base, you can use the same LCL equation (see the Water Vapor chapter) to estimate the pressure P_{cf} at the outside of the tornado condensation funnel, knowing the ambient air temperature T and dew point T_d at ambient near-surface pressure P . Namely, $P_{cf} = P_{LCL}$.

$$P_{cf} = P \cdot \left[1 - b \cdot \left(\frac{T - T_d}{T} \right) \right]^{C_p/\mathfrak{R}} \quad \bullet(15.48)$$

where $C_p/\mathfrak{R} = 3.5$ and $b = 1.225$, both dimensionless, T and T_d in the numerator must be in the same units, and where T in the denominator must be in Kelvin.

Assuming both the condensation funnel and cloud base indicate the same pressure, the isobars must curve downward near the tornado (Fig. 15.36). Thus, the greatest horizontal pressure gradient associated with the tornado is near the ground (near “A” in Fig. 15.36). Drag at the ground slows the wind a bit there, which is why the fastest tangential winds in a tornado are found 15 to 150 m above ground.

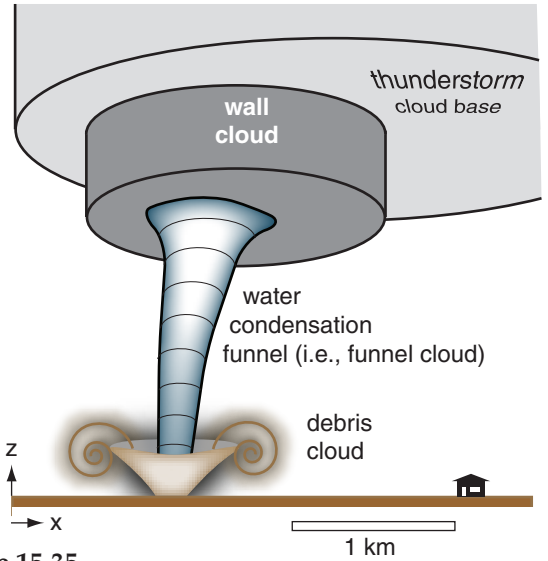

Figure 15.35
Condensation funnel and debris cloud.

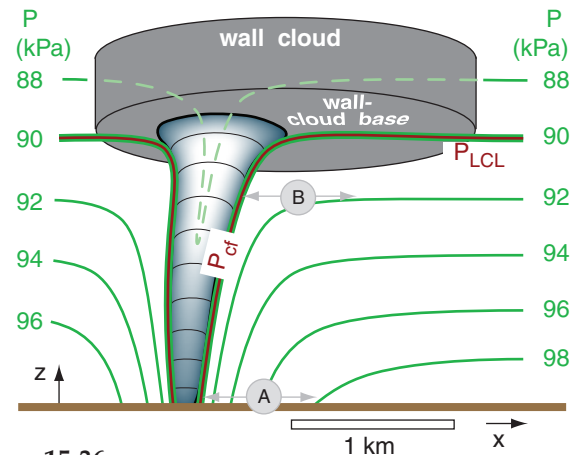

Figure 15.36
Relationship between lifting-condensation-level pressure (P_{LCL}), cloud base, and pressure at the condensation funnel (P_{cf}). Horizontal pressure gradient at point “A” is 4 times that at “B”.

Sample Application

Under a tornadic thunderstorm, the temperature is 30°C and dew point is 23°C near the ground where pressure is 100 kPa. Find the near-surface pressure at the outside edge of the visible condensation funnel.

Find the Answer

Given: $T = 30^\circ\text{C} = 303\text{K}$, $T_d = 23^\circ\text{C}$, $P = 100\text{ kPa}$
Find: $P_{cf} = ?\text{ kPa}$

Use eq. (15.48): $P_{cf} = (100\text{kPa}) \cdot [1 - 1.225 \cdot (30 - 23) / 303]^{3.5} = \underline{90.4\text{ kPa}}$ at the tornado funnel-cloud edge.

Check: Units OK. Physics OK.

Exposition: The tornado core pressure can be even lower than at the edge of the condensation funnel.

15.4.3. Types of Tornadoes & Other Vortices

We will compare six types of vortices (Fig 15.37):

- supercell tornadoes
- landspout tornadoes
- waterspouts
- cold-air funnels
- gustnadoes
- dust devils, steam devils, firewhirls

Recall from the Thunderstorm chapter that a **mesocyclone** is where the whole thunderstorm updraft (order of 10 to 15 km diameter) is slowly rotating (often too slowly to see by eye). This rotation can last for 1 h or more, and is one of the characteristics of a **supercell** thunderstorm. Only a small percentage of thunderstorms are supercells with mesocyclones, but it is from these supercells that the strongest tornadoes can form. Tornadoes rotate faster and have smaller diameter (~100 m) than mesocyclones.

Supercell tornadoes form under (and are attached to) the main updraft of supercell thunderstorms (Figs. 15.32a-c, 15.35, & 15.37) or under a cumulus congestus that is merging into the main supercell updraft from the flanking line. It can be the most violent tornado type — up through EF5 intensity. They move horizontally (i.e., **translate**) at nearly the same speed as the parent thunderstorm (on the order of 5 to 40 m s⁻¹). These tornadoes will be discussed in more detail in the next subsections.

Landspouts are weaker tornadoes (EF0 - EF2, approximately) not usually associated with supercell thunderstorms. They are often cylindrical, and look like hollow soda straws (Fig. 15.32d). These short-lived tornadoes form along strong cold fronts. Horizontal wind shear across the frontal zone provides the rotation, and vertical stretching of the air by updrafts in the **squall-line thunderstorms** along the front can intensify the rotation (Fig. 15.37).

Waterspouts (Fig. 15.37) are tornadoes that usually look like landspouts (hollow, narrow, 3 to 100 m diameter cylinders), but form over water surfaces (oceans, lakes, wide rivers, bays, etc.). They are often observed in subtropical regions (e.g., in the waters around Florida), and can form under (and are attached to) cumulus congestus clouds and small thunderstorms. They are often short lived (usually 5 to 10 min) and weak (EF0 - EF1). The waterspout life cycle is visible by eye via changes in color and waves on the water surface: (1) dark spot, (2) spiral pattern, (3) spray-ring, (4) mature spray vortex, and (5) decay. Waterspouts have also been observed to the lee of mountainous islands such as Vancouver Island, Canada, where the initial rotation is caused by wake vortices as the wind swirls around the sides of mountains.

Unfortunately, whenever any type of tornado moves over the water, it is also called a waterspout.

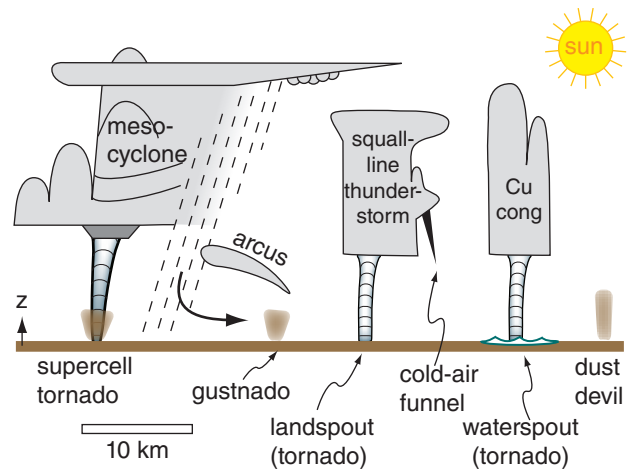

Figure 15.37
Illustration of tornado and vortex types.

Thus, supercell tornadoes (EF3 - EF5) would be called waterspouts if they moved over water. So use caution when you hear waterspouts reported in a weather warning, because without other information, you won't know if it is a weak classical waterspout or a strong tornado.

Cold-air funnels are short vortices attached to shallow thunderstorms with high cloud bases, or sometimes coming from the sides of updraft towers (Fig. 15.37). They are very short lived (1 - 3 minutes), weak, and usually don't reach the ground. Hence, they usually cause no damage on the ground (although light aircraft should avoid them). Cold-air funnels form in synoptic cold-core low-pressure systems with a deep layer of unstable air.

Gustnadoes are shallow (order of 100 m tall) debris vortices touching the ground (Fig. 15.37). They form along the gust-front from thunderstorms, where there is shear between the outflow air and the ambient air. Gustnadoes are very weak (EF0 or weaker) and very short lived (a few minutes). The arc clouds along the gust front are not usually convective, so there is little or no updraft to stretch the air vertically, and hence no mechanism for accelerating the vorticity. There might also be rotation or a very small condensation funnel visible in the overlying arc clouds. Gustnadoes translate with the speed of advance of the gust front.

Dust devils are not tornadoes, and are not associated with thunderstorms. They are fair-weather phenomena, and can form in the clear-air thermals of warm air rising from a heated surface (Fig. 15.37). They are weak (less than EF0) debris vortices, where the debris can be dust, sand, leaves, volcanic ash, grass, litter, etc. Normally they form during daytime in high-pressure regions, where the sun heats the ground, and are observed over the desert or oth-

er arid locations. They translate very slowly or not at all, depending on the ambient wind speed.

When formed by arctic-air advection over an unfrozen lake in winter, the resulting **steam-devils** can happen day or night. Smoky air heated by forest fires can create **firewhirls**. Dust devils, steam devils, firewhirls and gustnadoes look very similar.

15.4.4. Evolution as Observed by Eye

From the ground, the first evidence of an incipient supercell tornado is a **dust swirl** near the ground, and sometimes a rotating wall cloud protruding under the thunderstorm cloud base (Fig. 15.38). Stage 2 is the **developing stage**, when a condensation funnel cloud begins to extend downward from the bottom of the wall cloud or thunderstorm base, and the debris cloud becomes larger with well-defined rotation.

Stage 3 is the **mature stage**, when there is a visible column of rotating droplets and/or debris extending all the way from the cloud to the ground. This is the stage when tornadoes are most destructive. During stage 4 the visible tornado weakens, and often has a slender rope-like shape (also in Fig. 15.32f). As it dissipates in stage 5, the condensation funnel disappears up into the cloud base and the debris cloud at the surface weakens and disperses in the ambient wind. Meanwhile, a cautious storm chaser will also look to the east or southeast under the same thunderstorm cloud base, because sometimes new tornadoes form there.

15.4.5. Tornado Outbreaks

A **tornado outbreak** is when a single synoptic-scale system (e.g., cold front) spawns ten or more tornadoes during one to seven days (meteorologists are still debating a more precise definition). Tornado outbreaks have been observed every decade in North America for the past couple hundred years of recorded meteorological history. Outbreaks often occur one or more times each year.

The following list highlights a small portion of the outbreaks in North America:

- 25 May - 1 June 1917: 63 tornadoes in Illinois killed 383 people.
- 18 March 1925 (tri-state) Tornado: Deadliest tornado(es) in USA, killing 695 people on a 350 km track through Missouri, Illinois & Indiana.
- 1 - 9 May 1930: 67 tornadoes in Texas killed 110.
- 5 - 6 April 1936: 17 tornadoes in Tupelo, Mississippi, and Gainesville, Georgia, killed 454.
- 7 - 11 April 1965 (Palm Sunday): 51 F2 - F5 tornadoes, killed 256.
- 3 - 4 April 1974: 148 tornadoes, killed 306 people in Midwest USA, and 9 in Canada.

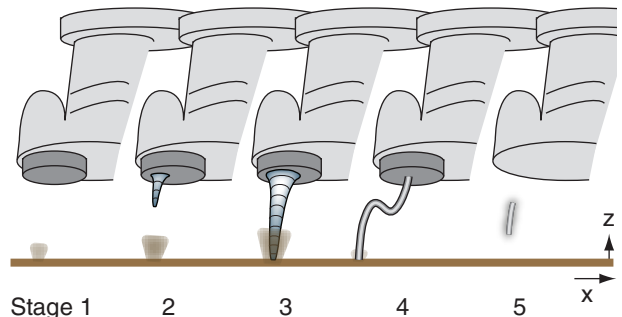

Figure 15.38

Stages in a supercell-tornado life cycle. Caution: the EF intensity of some tornadoes can fluctuate while the tornado is in its mature stage (stage 3).

A SCIENTIFIC PERSPECTIVE • Be Safe (part 4)

More chase guidelines from Charles Doswell III.

The #3 Threat: The Storm

1. Avoid driving through the heaviest precipitation part of the storm (known as “**core punching**”).
2. Avoid driving under, or close to, rotating wall clouds.
3. Don't put yourself in the path of a tornado or a rotating wall cloud.
4. You must also be aware of what is happening around you, as thunderstorms and tornadoes develop quickly. You can easily find yourself in the path of a new thunderstorm while you are focused on watching an older storm. Don't let this happen — be vigilant.
5. For new storm chasers, find an experienced chaser to be your mentor. (Work out such an arrangement ahead of time; don't just follow an experienced chaser uninvited.)
6. Keep your engine running when you park to view the storm.
7. Even with no tornado, straight-line winds can move hail or debris (sheet metal, fence posts, etc.) fast enough to kill or injure you, and break car windows. Move away from such regions.
8. Avoid areas of rotating curtains of rain, as these might indicate that you are in the dangerous center of a mesocyclone (called the “**bear's cage**”).
9. Don't be foolhardy. Don't be afraid to back off if your safety factor decreases.
10. Never drive into rising waters. Some thunderstorms such as HP supercell storms can cause flash floods.
11. Always have a clear idea of the structure, evolution, and movement of the storm you are viewing, so as to anticipate safe courses of action.

(continues on next page)

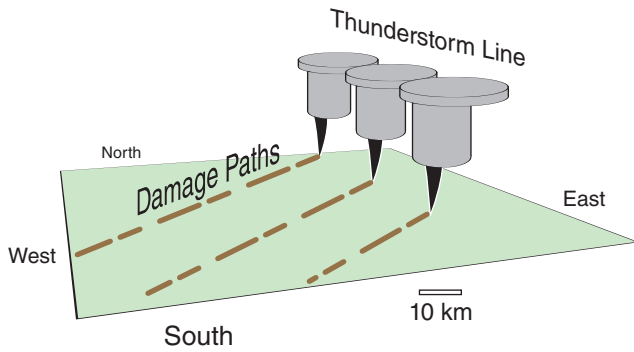

Figure 15.39

Sketch of parallel damage paths from a line of supercell thunderstorms during a tornado outbreak.

A SCIENTIFIC PERSPECTIVE • Be Safe (part 5)

More chase guidelines from Charles Doswell III.

The #3 Threat: The Storm (continuation)

12. Plan escape routes in advance.
13. Although vehicles offer safety from lightning, they are death traps in tornadoes. If you can't drive away from the tornado, then abandon your vehicle and get into a ditch or culvert, or some other place below the line-of-fire of flying debris.
14. In open rural areas with good roads, you can often drive away from the tornado's path.
15. Don't park under bridge overpasses, because winds accelerate there & cause increased damage.
16. Avoid chasing at night. Keep in mind the following challenges:
 - a. Storm movement as broadcast on radio or TV cannot be trusted. Often, the media reports the heavy precipitation areas, not the action (dangerous) areas of the mesocyclone and tornado.
 - b. Storm info provided via various wireless data and internet services can be several minutes old or older.
 - c. It is difficult to see tornadoes at night. Flashes of light from lightning & exploding electrical transformers (known as "**power flashes**") are often inadequate to see the tornado. Also, not all power flashes are caused by tornadoes.
 - d. If you find yourself in a region of strong inflow winds that are backing (changing direction counterclockwise), then you might be in the path of a tornado.
 - e. Flooded roads are hard to see at night, and can cut off your escape routes. Your vehicle could hydroplane due to water on the road, causing you to lose control.
 - f. Even after you stop chasing storms for the day, dangerous weather can harm you on your drive home or in a motel.

On his web site, Doswell offers many more tips and recommendations for responsible storm chasing.

- 31 May 1985: 41 tornadoes near the USA-Canada border killed 76 in USA and 12 in Canada.
- 3 - 11 May 2003: 401 tornadoes in **tornado alley** (central USA) killed 48.
- September 2004 in Hurricanes Francis & Ivan: 220 tornadoes.
- 22 - 25 May 2008: 234 tornadoes in central USA killed 10.
- 25 - 28 April 2011: 362 tornadoes in E. USA, killed 324, causing about \$10 billion in damage.
- 21 - 26 May 2011: 241 tornadoes in midwest USA killed 178.

Outbreaks are often caused by a line or cluster of supercell thunderstorms. Picture a north-south line of storms, with each thunderstorm in the line marching toward the northeast together like troops on parade (Fig. 15.39). Each tornadic supercell in this line might create a sequence of multiple tornadoes (called a **tornado family**), with very brief gaps between when old tornadoes decay and new ones form. The aftermath includes parallel tornado damage paths like a wide (hundreds of km) multi-lane highway oriented usually from southwest toward northeast in North America.

15.4.6. Storm-relative Winds

Because tornadoes translate with their parent thunderstorms, the winds that influence supercell and tornado rotation are the environmental wind vectors relative to a coordinate system that moves with the thunderstorm. Such winds are called **storm-relative (SR) winds**.

First, find the storm motion vector. If the thunderstorm already exists, then its motion can be tracked on radar or satellite (which gives a vector based on its actual speed and direction of movement). For forecasts of future thunderstorms, recall from the previous chapter that many thunderstorms move in the direction of the mean wind averaged over the 0 to 6 km layer of air, as indicated by the "X" in Fig. 15.40. Some supercell storms split into two parts: a right moving storm and a left moving storm, as was shown in the Thunderstorm Fundamentals chapter. Namely, if tornado formation from a right-moving supercell is of concern, then a mean storm vector associated with the "R" in Fig. 14.61 of the previous chapter should be used (i.e., do not use the "X"). See the Sample Application below, for an example.

Next, to find storm-relative winds, take the vector difference between the actual wind vectors and the storm-motion vector. On a hodograph, draw the storm-relative wind vectors from the storm-motion point to each of the original wind-profile data points. This is illustrated in Fig. 15.40a, based on

the hodograph and normal storm motion “X”. After (optionally) repositioning the hodograph origin to coincide with the mean storm motion (Fig. 15.40b), the result shows the directions and speed of the storm-relative environmental wind vectors.

The algebraic components (U_j', V_j') and magnitude M' of these storm-relative horizontal vectors are:

$$U_j' = U_j - U_s \quad \bullet(15.49a)$$

$$V_j' = V_j - V_s \quad \bullet(15.49b)$$

$$M_j' = (U_j'^2 + V_j'^2)^{1/2} \quad (15.50)$$

where (U_j, V_j) are the horizontal wind components at height index j , and the storm motion vector is (U_s, V_s). For a supercell that moves with the 0 to 6 km mean wind: (U_s, V_s) = (\bar{U}, \bar{V}) from the previous chapter. The vertical component of storm-relative winds $W_j' = W_j$ because the thunderstorm does not translate vertically.

Most supercells have storm-relative winds of $M' = 7$ to 10 m s^{-1} at low altitudes [0 - 2 km above ground level (agl)] in the pre-storm environment. Environmental SR winds can also help you anticipate the type of supercell that might occur. Let M'_{anvil} be SR winds at the storm top (9 - 11 km agl).

- $M'_{anvil} < 20 \text{ m s}^{-1}$ favors high-precipitation (HP) supercells
- $20 \text{ m s}^{-1} \leq M'_{anvil} < 30 \text{ m s}^{-1}$ favors classic supercells
- $30 \text{ m s}^{-1} \leq M'_{anvil}$ favors low-precipitation (LP) supercells

15.4.7. Origin of Tornadoic Rotation

Because tornado rotation is around a vertical axis, this rotation can be expressed as a **relative vertical vorticity** ζ_r . Relative vorticity was defined in the General Circulation chapter as $\zeta_r = (\Delta V / \Delta x) - (\Delta U / \Delta y)$,

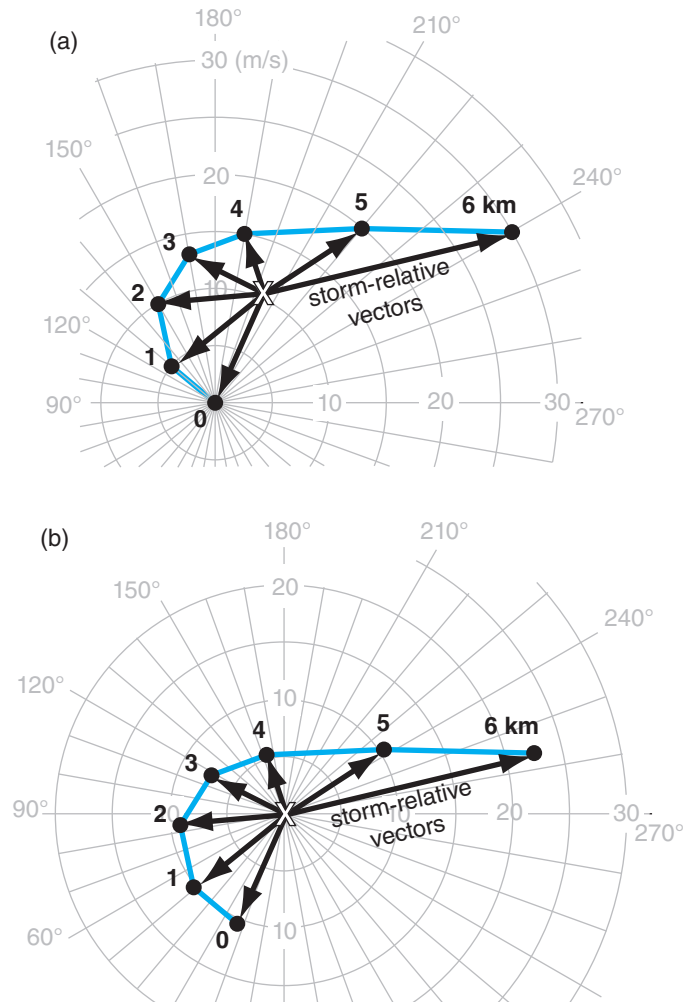

Figure 15.40

(a) Hodograph showing wind vector differences between the winds relative to a fixed-coordinate system (blue line hodograph) and the mean storm motion (X), based on the data from Figs. 14.57 & 14.59. (b) Same data, but with the hodograph origin shifted to “X” to give **storm-relative** wind vectors (black arrows). Some people find version (b) difficult to interpret, so they prefer to use version (a).

Sample Application

For the right-moving supercell of Fig. 14.61 from the previous chapter plot the storm-relative wind vectors on a hodograph.

Find the Answer

Given: Fig. 14.61. Storm motion indicated by “R”.
Find: Hodograph of storm-relative winds.

Method: Copy Fig. 14.61, draw relative vectors on it, and then re-center origin of hodograph to be at “R”:

Check: Similar to Fig. 15.40b.

Exposition: Compared to storm “X”, storm “R” has less directional shear, but more inflow at middle altitudes.

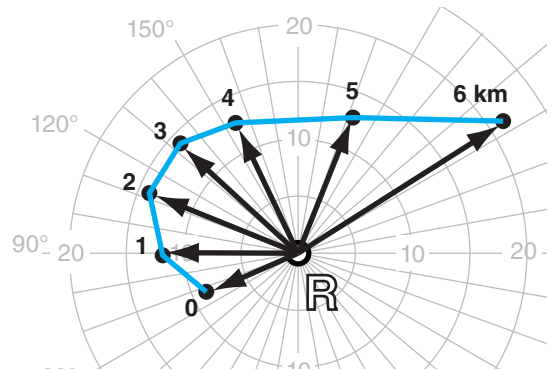

Sample Application

Given storm-relative horizontal wind shear in the environment of $\Delta U'/\Delta z$ of 15 m s^{-1} across 3 km of height, find the vorticity spin-up if vertical velocity increases from 0 to 10 m s^{-1} across $\Delta y=10 \text{ km}$.

Find the Answer

Given: $\Delta U'/\Delta z = (15 \text{ m s}^{-1})/(3 \text{ km}) = 5 \times 10^{-3} \text{ s}^{-1}$

$\Delta W/\Delta y = (10 \text{ m s}^{-1})/(10 \text{ km}) = 1 \times 10^{-3} \text{ s}^{-1}$

Find: $\Delta \zeta_r/\Delta t = ? \text{ s}^{-2}$

Assume: All other terms in eq. (15.51) are negligible.

$$\Delta \zeta_r/\Delta t = (5 \times 10^{-3} \text{ s}^{-1}) \cdot (1 \times 10^{-3} \text{ s}^{-1}) = \underline{5 \times 10^{-6} \text{ s}^{-2}}$$

Check: Units OK. Physics OK.

Exposition: Tilting by itself might create a mesocyclone, but is too weak to create a tornado.

and a forecast (tendency) equation for it was given in the Extratropical Cyclone chapter in the section on cyclone spin-up.

Relative to the thunderstorm, there is little horizontal or vertical advection of vertical vorticity, and the beta effect is small because any one storm moves across only a small range of latitudes during its lifetime. Thus, mesocyclone and tornadic vorticity are affected mainly by tilting, stretching, and turbulent drag:

$$\frac{\Delta \zeta_r}{\Delta t} \approx \underbrace{\frac{\Delta U'}{\Delta z} \cdot \frac{\Delta W}{\Delta y}}_{\text{spin-up}} - \underbrace{\frac{\Delta V'}{\Delta z} \cdot \frac{\Delta W}{\Delta x}}_{\text{tilting}} \tag{15.51}$$

$$+ (\zeta_r + f_c) \cdot \underbrace{\frac{\Delta W}{\Delta z}}_{\text{stretching}} - C_d \cdot \underbrace{\frac{M}{z_{\text{TornBL}}}}_{\text{turb.drag}} \cdot \zeta_r$$

where the storm-relative wind components are (U' , V' , W), the Coriolis parameter is f_c , the tangential wind speed is approximately M , drag coefficient is C_d , and z_{TornBL} is the depth of the tornado's boundary layer (roughly 100 m).

This simplified vorticity-tendency equation says that rotation about a vertical axis can increase (i.e., **spin up**) if horizontal vorticity is **tilted** into the vertical, or if the volume of air containing this vertical vorticity is **stretched** in the vertical (Fig. 15.41). Also, cyclonically-rotating tornadoes (namely, rotating in the same direction as the Earth's rotation, and having positive ζ_r) are favored slightly, due to the Coriolis parameter in the stretching term. Rotation decreases due to **turbulent drag**, which is greatest at the ground in the tornado's boundary layer.

Most theories for tornadic rotation invoke tilting and/or stretching of vorticity, but these theories disagree about the origin of rotation. There is some evidence that different mechanisms might trigger different tornadoes.

Two theories focus on rotation about a horizontal axis in the atmospheric boundary layer. One theory suggests that **streamwise vorticity** (rotation about a horizontal axis aligned with the mean wind direction) exists in ambient (outside-of-the-storm) air due to vertical shear of the horizontal wind $\Delta U/\Delta z$ in Fig. 15.42a. Once this air reaches the inflow region of the thunderstorm, the horizontal streamwise vorticity is tilted by convective updrafts to create rotation around a vertical axis.

Another theory considers shears in vertical velocity that develop near the ground where cool precipitation-induced downdrafts are adjacent to warm updrafts. The result is vorticity about a nearly hori-

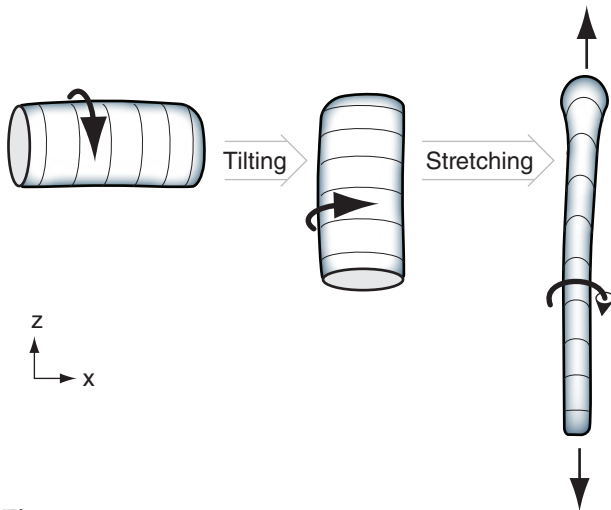

Figure 15.41

Tilting can change rotation about a horizontal axis to rotation about a vertical axis, to create a mesocyclone (a rotating thunderstorm). Stretching can then intensify the rotation into a tornado.

zonal axis (Fig. 15.42b), which can be tilted towards vertical by the downdraft air near the ground.

Two other theories utilize thunderstorm updrafts to stretch existing cyclonic vertical vorticity. One suggests that the precipitation-cooled downdraft will advect the mesocyclone base downward, thereby stretching the vortex and causing it to spin faster. Such a mechanism could apply to mesoscale convective vortices (MCVs) in the mid troposphere. The other theory considers thunderstorm updrafts that advect the top of the mesocyclone upward — also causing stretching and spin-up.

Another theory suggests that large-scale rotation about a vertical axis of a synoptic-scale cyclone can cascade down to medium (mesocyclone) scales and finally down to small (tornadic) scales. All of these previous theories are for supercell tornadoes.

Weaker tornadoes are suggested to form at boundaries between cold and warm airmasses near the ground. The cold airmass could be the result of precipitation-cooled air that creates a downdraft and associated outflow winds. At the airmass boundary, such as a cold front or gust front, cold winds on one side of the boundary have an along-boundary component in one direction while the warmer winds on the other side have an along-boundary component in the opposite direction. The vertical vorticity associated with these shears ($\Delta U/\Delta y$ and $\Delta V/\Delta x$) can be stretched to create **landspouts** and **gustnadoes**.

15.4.8. Helicity

Many of the previous theories require a mesocyclone that has both rotation and updraft (Fig. 15.43a). The combination of these motions describes a helix (Fig. 15.43b), similar to the shape of a corkscrew.

Define a scalar variable called **helicity**, H , at any one point in the air that combines rotation around some axis with mean motion along the same axis:

$$H = U_{avg} \cdot \left[\frac{\Delta W}{\Delta y} - \frac{\Delta V}{\Delta z} \right] + V_{avg} \cdot \left[-\frac{\Delta W}{\Delta x} + \frac{\Delta U}{\Delta z} \right] + W_{avg} \cdot \left[\frac{\Delta V}{\Delta x} - \frac{\Delta U}{\Delta y} \right] \tag{15.52}$$

where $U_{avg} = 0.5 \cdot (U_{j+1} + U_j)$ is the average U -component of wind speed between height indices j and $j+1$. V_{avg} and W_{avg} are similar. $\Delta U/\Delta z = (U_{j+1} - U_j)/(z_{j+1} - z_j)$, and $\Delta V/\Delta z$ and $\Delta W/\Delta z$ are similar. Helicity units are $m \cdot s^{-2}$, and the differences Δ should be across very small distances.

If the ambient environment outside the thunderstorm has only vertical shear of horizontal winds, then eq. (15.52) can be simplified to be:

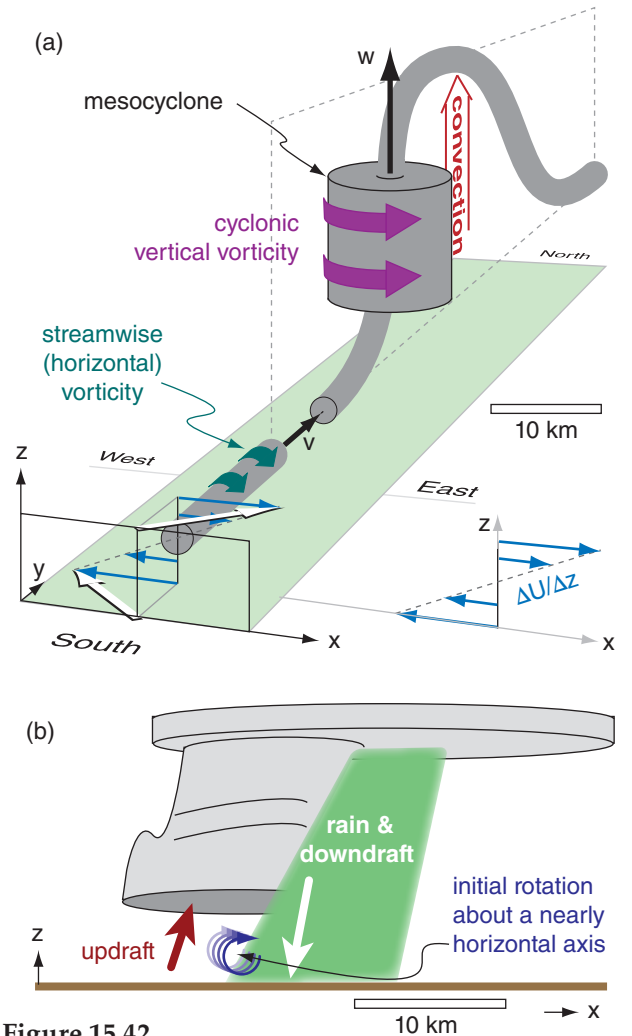

Figure 15.42 Theories for creation of initial rotation about a horizontal axis. (a) Vertical shear of the horizontal wind ($\Delta U/\Delta z$) causes streamwise horizontal vorticity (dark slender horizontal cylinder), which can be tilted by convective updrafts to create mesocyclones (fat vertical cylinder). This wind profile is typical of the prairies in central North America. (b) Shear between thunderstorm downdraft and updraft creates rotation close to the ground with a horizontal axis that can be tilted to vertical.

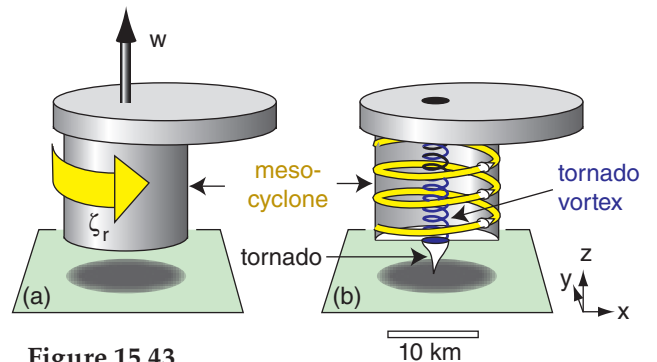

Figure 15.43 (a) Sketch of a supercell thunderstorm showing both mesocyclone rotation (yellow arrow) and updraft (black arrow). (b) Cross-section showing helical motions (yellow arrows) in the mesocyclone and smaller-diameter but faster rotation of the tornado vortex (dark-blue helix). ζ_r is relative vorticity, and w is vertical velocity.

Sample Application

(a) Given the velocity sounding below, what is the associated streamwise helicity?

z (km)	U (m s ⁻¹)	V (m s ⁻¹)
1	1	7
2	5	9

(b) If a convective updraft of 12 m s⁻¹ tilts the streamwise vorticity from (a) into the vertical while preserving its helicity, what is the vertical vorticity value?

Find the Answer

Given: (a) in the table above (b) $w = 12 \text{ m s}^{-1}$
 Find: (a) $H = ? \text{ m}\cdot\text{s}^{-2}$ (b) $\zeta_r = ? \text{ s}^{-1}$

(a) First find the average wind between the two given heights [$U_{avg} = (1+5)/2 = 3 \text{ m s}^{-1}$. Similarly $V_{avg} = 8 \text{ m s}^{-1}$]. Then use eq. (15.53):

$$H \approx (8\text{m/s}) \cdot \frac{(5-1\text{m/s})}{(2000-1000\text{m})} - (3\text{m/s}) \cdot \frac{(9-7\text{m/s})}{(2000-1000\text{m})}$$

$$= 0.032 + 0.006 \text{ m}\cdot\text{s}^{-2} = \mathbf{0.038 \text{ m}\cdot\text{s}^{-2}}$$

(b) Use this helicity in eq. (15.54):
 $(0.038 \text{ m}\cdot\text{s}^{-2}) = (12\text{m}\cdot\text{s}^{-1}) \cdot \zeta_r$. Thus, $\zeta_r = \mathbf{0.0032 \text{ s}^{-1}}$

Check: Physics & units OK.

Exposition: Time lapse photos of mesocyclones show rotation about 100 times faster than for synoptic lows.

$$H \approx V_{avg} \cdot \frac{\Delta U}{\Delta z} - U_{avg} \cdot \frac{\Delta V}{\Delta z} \quad \bullet(15.53)$$

which gives only **streamwise-vorticity** contribution to the total helicity. Alternatively, if there is only rotation about a vertical axis, then eq. (15.52) can be simplified to give the vertical-relative-vorticity ζ_r contribution to total helicity:

$$H = W_{avg} \cdot \left[\frac{\Delta V}{\Delta x} - \frac{\Delta U}{\Delta y} \right] = W_{avg} \cdot \zeta_r \quad \bullet(15.54)$$

If helicity H is preserved while thunderstorm up- and down-drafts tilt the streamwise vorticity into vertical vorticity, then you can equate the H values in eqs. (15.53) and (15.54). This allows you to forecast mesocyclone rotation for any given shear in the pre-storm environment. Greater values of streamwise helicity in the environment could increase the relative vorticity of a mesocyclone, making it more **tornadogenic** (tending to spawn new tornadoes).

More useful for mesocyclone and tornado forecasting is a **storm relative helicity (SRH)**, which uses storm-relative environmental winds (U', V') to get a relative horizontal helicity contribution H' . Substituting storm-relative winds into eq. (15.53) gives:

$$H' \approx V'_{avg} \cdot \frac{\Delta U'}{\Delta z} - U'_{avg} \cdot \frac{\Delta V'}{\Delta z} \quad (15.55)$$

where $U'_{avg} = 0.5 \cdot (U'_{j+1} + U'_j)$ is the average U' -component of wind within the layer of air between height indices j and $j+1$, and V'_{avg} is found similarly.

To get the overall effect on the thunderstorm, SRH then sums H' over all atmospheric layers within the inflow region to the thunderstorm, multiplied by the thickness of each of those layers.

$$SRH = \sum H' \cdot \Delta z \quad \bullet(15.56)$$

$$= \sum_{j=0}^{N-1} [(V'_j \cdot U'_{j+1}) - (U'_j \cdot V'_{j+1})] \quad \bullet(15.57)$$

where N is the number of layers, $j = 0$ is the bottom wind-observation index (usually at the ground, $z = 0$), and $j = N$ is the top wind-observation index (at the top of the inflow region). Normally, the inflow region spans all atmospheric layers from the ground to 1 or 3 km altitude. Units of SRH are $\text{m}^2\cdot\text{s}^{-2}$.

On a hodograph, the SRH is twice the area swept by the storm-relative wind vectors in the inflow region (Fig. 15.44).

In computer-simulated storms, an **updraft helicity** is defined as $\mathbf{UH} = \sum (W \cdot \zeta_r \cdot \Delta z)$, where the sum is over layers (each of thickness Δz) between 2 & 5 km altitude agl. UH units are $\text{m}^2\cdot\text{s}^{-2}$, similar to SRH.

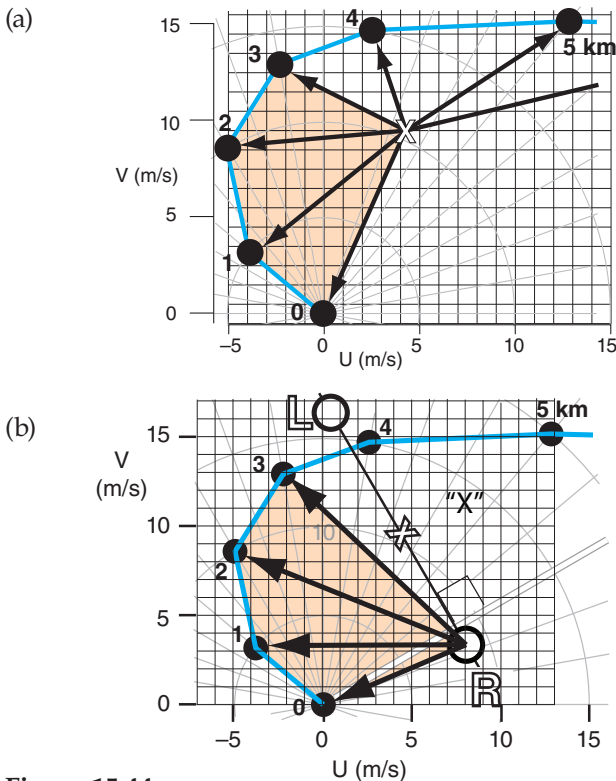

Figure 15.44
 Storm-relative helicity (SRH) between the surface and $z = 3 \text{ km}$ is twice the shaded area. But for any hodograph, you will likely get different areas for normal, left-moving, and right-moving storms. (a) For “normal” storm motion “X”, based on hodograph of Figs. 14.61 & 15.40a. (b) For right-moving storm motion “R”, based on the hodograph of Fig. 14.61.

SRH is an imperfect indicator of whether thunderstorms are likely to be supercells and form tornadoes, hail, and strong straight-line winds. Fig. 15.45 shows the relationship between SRH values and tornado strength. Some evidence suggests that the 0 to 1 km SRH (Fig. 15.46) is a slightly better indicator than SRH over the 0 to 3 km layer.

One difficulty with SRH is its sensitivity to storm motion. For example, hodographs of veering wind as plotted in Fig. 15.44 would indicate much greater SRH for a right moving (“R”) storm compared to a supercell that moves with the average 0 to 6 km winds (“X”). For this reason, observed storm motion give better SRH estimates than predicted motion.

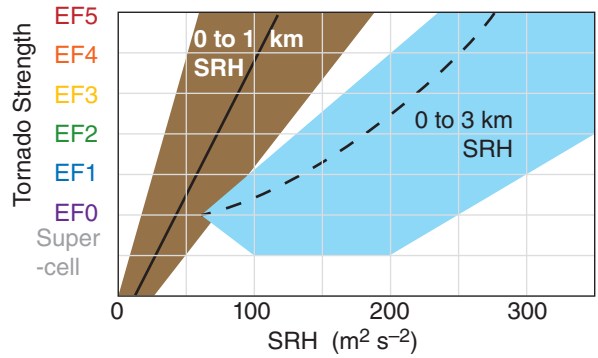

Figure 15.45
Approximate relationship between storm-relative helicity (SRH) and tornado strength on the Enhanced Fujita scale (EF0 to EF5), for North America. “Supercell” indicates a non-tornadic mesocyclonic thunderstorm. Caution: the shaded domain boundaries are not as sharp as drawn. Solid and dashed lines are medians.

Sample Application

For the hodograph of Fig. 15.44a, graphically find SRH for the (a) $z = 0$ to 3 km layer, and (b) 0 to 1 km layer. (c, d) Find the SRHs for those two depths using an equation method. (e) Discuss the potential for tornadoes?

Find the Answer:

Given Fig. 15.44a.

Find: 0-3 km & 0-1 km SRH = ? $m^2 \cdot s^{-2}$,
both graphically & by eq.

a) Graphical method: Fig. 15.44a is copied below, and zoomed into the shaded region. Count squares in the shaded region of the fig., knowing that each square is $1 m s^{-1}$ by $1 m s^{-1}$, and thus spans $1 m^2 \cdot s^{-2}$ of area.

When counting squares, if a shaded area (such as for square #2 in the fig. below) does not cover the whole square, then try to compensate with other portions of shaded areas (such as the small shaded triangle just to the right of square #2).

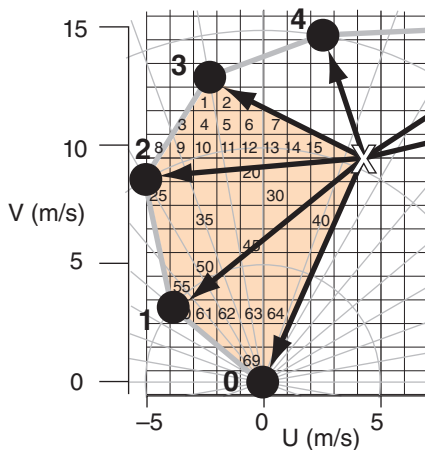

Thus, for 0 to 3 km SRH:
SRH = 2 · (# of squares) · (area of each square)
SRH = 2 · (69 squares) · ($1 m^2 \cdot s^{-2} / \text{square}$) = **$138 m^2 \cdot s^{-2}$** .

b) For 0 to 1 km: SRH:
SRH = 2 · (25 squares) · ($1 m^2 \cdot s^{-2} / \text{square}$) = **$50 m^2 \cdot s^{-2}$** .
(continues in next column)

Sample Application (SRH continuation)

c) Equation method: Use eq. (15.57). For our hodograph, each layer happens to be 1 km thick. Thus, the index j happens to correspond to the altitude in km of each wind observation, for this fortuitous situation.

For the 0-3 km depth, eq. (15.57) expands to be:
SRH = $V'_0 \cdot U'_1 - U'_0 \cdot V'_1$ (for $0 \leq z \leq 1$ km)
+ $V'_1 \cdot U'_2 - U'_1 \cdot V'_2$ (for $1 \leq z \leq 2$ km)
+ $V'_2 \cdot U'_3 - U'_2 \cdot V'_3$ (for $2 \leq z \leq 3$ km)

Because the figure at left shows storm-relative winds, we can pick off the (U', V') values by eye at each level:

z (km)	U' ($m s^{-1}$)	V' ($m s^{-1}$)
0	-4.3	-9.5
1	-8.1	-6.2
2	-9.3	-1.0
3	-7.7	+3.3

Plugging these values into the eq. above gives:

$$\begin{aligned} \text{SRH} &= (-9.5) \cdot (-8.1) - (-4.3) \cdot (-6.2) \\ &+ (-6.2) \cdot (-9.3) - (-8.1) \cdot (-1.0) \\ &+ (-1.0) \cdot (-7.7) - (-9.3) \cdot (+3.3) \\ \text{SRH} &= 76.95 - 26.66 + 57.66 - 8.1 + 7.7 + 30.69 \\ &= \mathbf{138.2 m^2 \cdot s^{-2}} \text{ for } 0 - 3 \text{ km} \end{aligned}$$

d) 0-1 km SRH = $76.95 - 26.66 = \mathbf{50.3 m^2 \cdot s^{-2}}$.

e) Using Fig. 15.45 there is a **good chance of supercells and EF0 to EF1 tornadoes. Slight chance of EF2 tornado.** However, Fig. 15.46 suggests a **supercell with no tornado.**

Check: Units OK. Physics OK. Magnitudes OK.

Exposition: The graphical and equation methods agree amazingly well with each other. This gives us confidence to use either method, whichever is easiest.

The disagreement in tornado potential between the 0-1 and 0-3 km SRH methods reflects the tremendous difficulty in thunderstorm and tornado forecasting. Operational meteorologists often must make difficult decisions quickly using conflicting indices.

INFO • Effective Inflow Layer for SRH

Consider the nighttime sounding plotted on the emagram in Fig. (a) below. An air parcel (filled and open circles representing T and T_d , respectively) lifted from 100 kPa would have very large CIN magnitude but no CAPE. Thus, cold air from 100 kPa would NOT likely be drawn into a thunderstorm.

An air parcel starting at 90 kPa from the same sounding (Fig. b) would have positive CAPE and small CIN. This is likely within the effective inflow layer, and is typical of a residual layer above a stable layer.

But the parcel starting from 80 kPa in Fig. (c) would not likely be in the effective inflow layer, because the CIN has greater magnitude but CAPE is weaker.

Computer programs can automatically test many more starting altitudes to pinpoint the effective inflow layer.

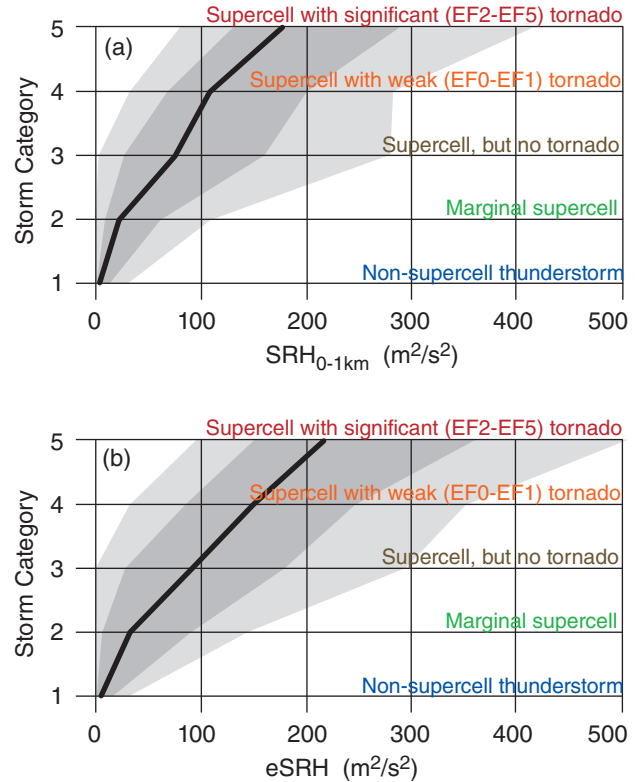
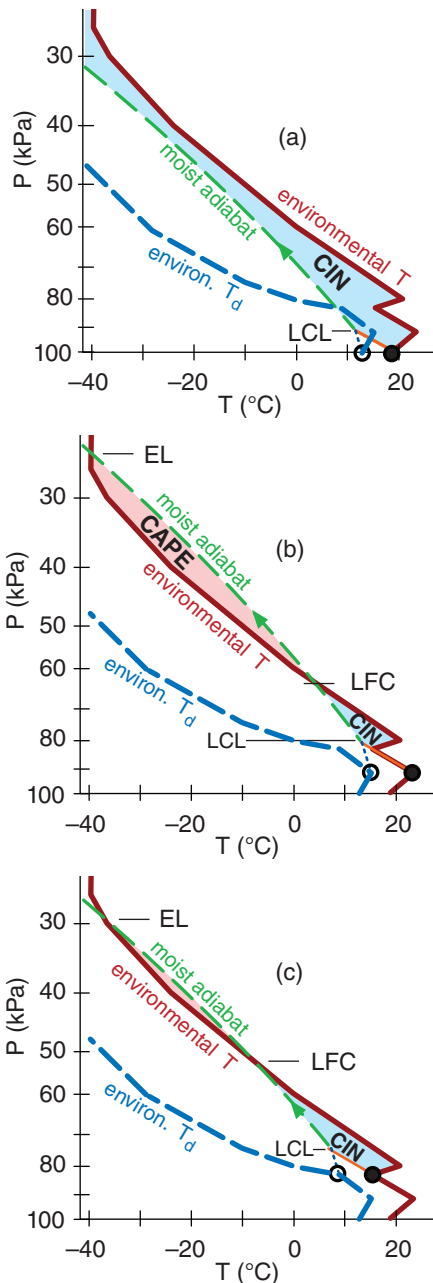

Figure 15.46
 Statistics of thunderstorm intensity vs. (a) storm-relative helicity (SRH) across a 0 to 1 km fixed-layer of air; and (b) effective storm-relative helicity (eSRH). For several hundred storms in central N. America, the black line is the median (50 percentile); dark grey shading spans 25th to 75th percentiles (the interquartile range); and light grey spans 10th to 90th percentiles.

Because thunderstorms do not necessarily draw in air from the 0 to 1 km layer, an **effective Storm Relative Helicity (eSRH)** has been proposed that is calculated across a range of altitudes that depends on CAPE and CIN of the environmental sounding. The bottom altitude, called the **effective-inflow base**, is found as the lowest starting altitude for a rising air parcel that satisfies two constraints: CAPE $\geq 100 \text{ J kg}^{-1}$ when lifted to its EL, and CIN $\geq -250 \text{ J kg}^{-1}$ (i.e., is less negative than -250 J kg^{-1}). The top altitude of the effective inflow layer is the lowest starting height (above the inflow base) for which rising air-parcel CAPE $\leq 100 \text{ J kg}^{-1}$ or CIN $\leq -250 \text{ J kg}^{-1}$. The INFO box at left illustrates this concept.

The eSRH calculation is made only if the top and bottom layer altitudes are within the bottom 3 km of the atmosphere. eSRH is easily found using computer programs. Fig. 15.47 shows a map of eSRH for the 24 May 2006 case.

Fig. 15.46b shows that eSRH better discriminates between non-tornadic and tornadic supercells than SRH. eSRH works even if the storm ingests residual-layer air that lies on top of a shallow stable layer

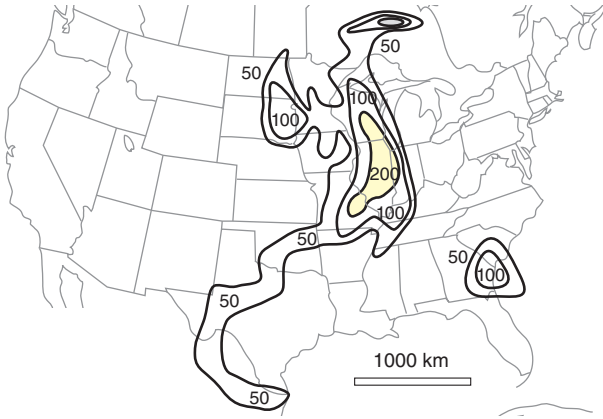

Figure 15.47
A case-study example of effective storm-relative helicity (eSRH) in units of $m^2 s^{-2}$ at 23 UTC on 24 May 2006, over the USA. Values of eSRH greater than $200 m^2 s^{-2}$ are shaded, and indicate locations of greatest likelihood for tornadic supercells.

of colder air, such as occurs at night, as illustrated in the INFO box at left.

As sketched in Fig. 15.43a, both updraft and rotation (vorticity) are important for mesocyclone formation. You might anticipate that the most violent supercells have both large CAPE (suggesting strong updrafts) and large SRH (suggesting strong rotation). A composite index called the **Energy Helicity Index (EHI)** combines these two variables:

$$EHI = \frac{CAPE \cdot SRH}{a} \quad \bullet(15.58)$$

where $a = 1.6 \times 10^5 m^4 s^{-4}$ is an arbitrary constant designed to make EHI dimensionless and to scale its values to lie between 0 and 5 or so. Large values of EHI suggest stronger supercells and tornadoes.

CAPE values used in EHI are always the positive area on the thermo diagram between the LFC and the EL. MLCAPE SRH values can be either for the 0 to 1 km layer in the hodograph, or for the 0 to 3 km layer. For this reason, EHI is often classified as 0-1 km EHI or 0-3 km EHI. Also, EHI can be found either from actual rawinsonde observations, or from forecast soundings extracted from numerical weather prediction models. An effective energy helicity index (eEHI) can also be calculated from eSRH.

Table 15-5 indicates likely tornado strength in North America as a function of 0-3 km EHI. Caution: the EHI ranges listed in this table are only approximate. If 0-1 km EHI is used instead, then significant tornadoes can occur for EHI as low as 1 or 2, such as shown in Fig. 15.48. To illustrate EHI, Fig. 15.49 shows a forecast weather map of EHI for 24 May 2006.

Table 15-5. Energy Helicity Index (0-3 km EHI) as an indicator of possible tornado existence and strength.

EHI	Tornado Likelihood
< 1.0	Tornadoes & supercells unlikely.
1.0 to 2.0	Supercells with weak, short-lived tornadoes possible. Non-supercell tornadoes possible (such as near bow echoes).
2.0 to 2.5	Supercells likely. Mesocyclone-induced tornadoes possible.
2.5 to 3.0	Mesocyclone-induced supercell tornadoes more likely.
3.0 to 4.0	Strong mesocyclone-induced tornadoes (EF2 and EF3) possible.
> 4.0	Violent mesocyclone-induced tornadoes (EF4 and EF5) possible.

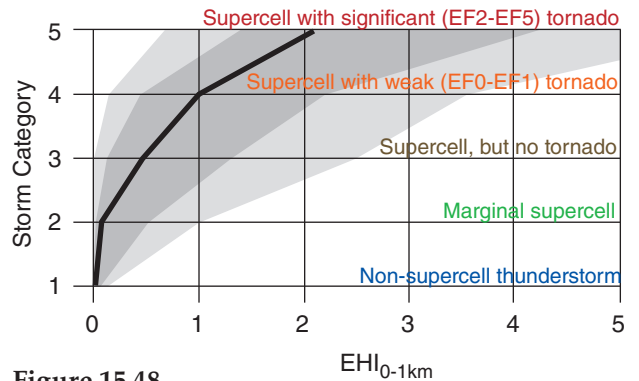

Figure 15.48
Statistics of thunderstorm intensity vs. energy helicity index (EHI) across a 0 to 1 km layer of air. For several hundred storms in central N. America, the black line is the median (50 percentile); dark grey shading spans 25th to 75th percentiles (the interquartile range); and light grey spans 10th to 90th percentiles.

Sample Application

Suppose a prestorm sounding shows that the convective available potential energy is $2000 J kg^{-1}$, and the storm relative helicity is $150 m^2 s^{-2}$ in the bottom 1 km of atmosphere. Find the value of energy helicity index, and forecast the likelihood of severe weather.

Find the Answer:

Given: $CAPE = 2000 J kg^{-1} = 2000 m^2 s^{-2}$,
 $SHR_{0-1km} = 150 m^2 s^{-2}$
 Find: $EHI = ?$ (dimensionless)

Use eq. (15.58):

$$EHI = (2000 m^2 s^{-2}) \cdot (150 m^2 s^{-2}) / (1.6 \times 10^5 m^4 s^{-4}) = \underline{1.88}$$

Check: Units dimensionless. Value reasonable.

Exposition: Using this value in Fig. 15.48, there is a **good chance for a tornadic supercell thunderstorm**, and the tornado could be significant (EF2 - EF5). However, there is a slight chance that the thunderstorm will be non-tornadic, or could be a marginal supercell.

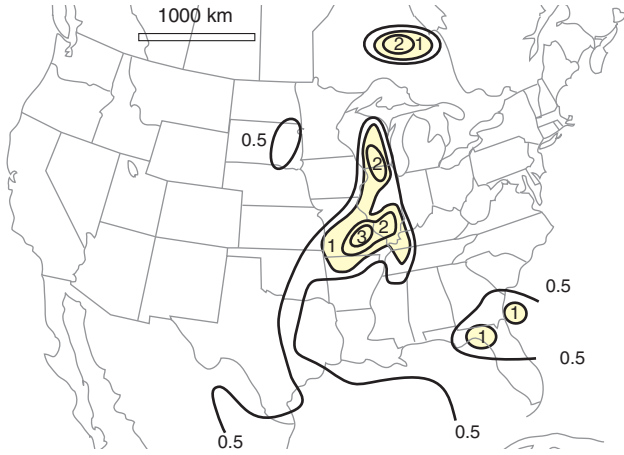

Figure 15.49
Map of energy helicity index (EHI) over the 0 to 1 km layer, for the 23 UTC case on 24 May 2006, over the USA. Dimensionless values greater than 1 are shaded, and suggest stronger supercell storms with greater likelihood of tornadoes.

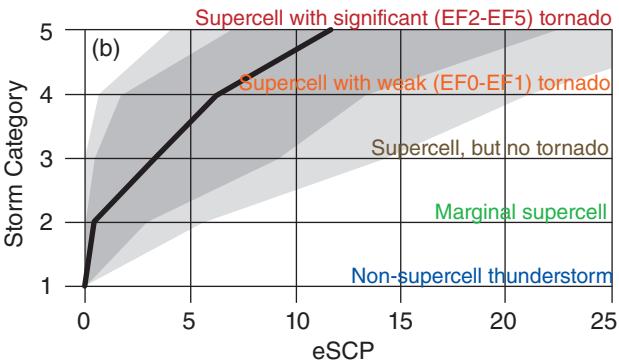

Figure 15.50
Statistics of thunderstorm intensity vs. effective Supercell Composite Parameter (eSCP). For several hundred *right-moving* storms in central N. America, the black line is the median (50th percentile); dark grey shading spans 25th to 75th percentiles (interquartile range); and light grey spans 10th to 90th percentiles.

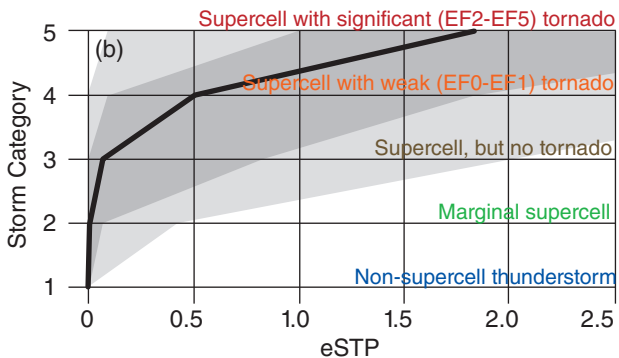

Figure 15.51
Statistics of thunderstorm intensity vs. effective Significant Tornado Parameter (eSTP). For several hundred storms in central N. America, the black line is the median (50th percentile); dark grey shading spans 25th to 75th percentiles (the interquartile range); and light grey spans 10th to 90th percentiles.

Because none of the forecast parameters and indices give perfect forecasts of supercells and tornadoes, researchers continue to develop and test other indices. One example is the effective **Supercell Composite Parameter (eSCP)**, defined by:

$$eSCP = (C/C_o) \cdot (H/H_o) \cdot (S/S_o) \quad (15.59)$$

where $C = \text{MUCAPE}$, $C_o = 1000 \text{ J kg}^{-1}$, $H = \text{eSRH}$, $H_o = 50 \text{ m}^2 \text{ s}^{-2}$, $S = \text{eBWD} = \text{effective bulk wind difference in the range of } 10 \text{ to } 20 \text{ m s}^{-1}$, and $S_o = 20 \text{ m s}^{-1}$. eSCP is set to zero if $S < 10 \text{ m s}^{-1}$. (S/S_o) is set to 1 if $S > S_o$. Fig. 15.50 shows how eSCP relates to right-moving supercells and tornadoes.

Another experimental parameter is the effective **Significant Tornado Parameter (eSTP)**, which is defined only when the inflow base is at the ground:

$$eSTP = (C/C_1) \cdot (\Delta L/L_1) \cdot (H/H_1) \cdot (S/S_1) \cdot (I+I_1)/I_r \quad (15.60)$$

where $C = \text{MLCAPE}$, $C_1 = 1500 \text{ J kg}^{-1}$, $\Delta L = [2000 \text{ m} - L]$ for $L = \text{ML.LCL}$, $L_1 = 1000 \text{ m}$, $H = \text{eSRH}$, $H_1 = 150 \text{ m}^2 \text{ s}^{-2}$, $S = \text{eBWD}$ in the range of 12.5 to 30 m s^{-1} , $S_1 = 20 \text{ m s}^{-1}$, $I = \text{ML.CIN}$, $I_1 = 200 \text{ J kg}^{-1}$, and $I_r = 150 \text{ J kg}^{-1}$. eSTP is set to zero if $S < 12.5 \text{ m s}^{-1}$. (S/S_1) is set to 1.5 if $S > 30 \text{ m s}^{-1}$. $(\Delta L/L_1)$ is set to 1 for $L < L_1$. $[(I+I_1)/I_r]$ is set to 1 for $I > -50 \text{ J kg}^{-1}$. Fig. 15.51 shows how eSTP relates to supercells and tornadoes.

15.4.9. Multiple-vortex Tornadoes

If conditions are right, a single parent tornado can develop multiple mini daughter-tornadoes around the parent-tornado perimeter near the ground (Fig. 15.52c). Each of these daughter vortices can have strong tangential winds and very low core pressure. These daughter tornadoes are also known as **suction vortices** or **suction spots**. **Multiple-vortex tornadoes** can have 2 to 6 suction vortices. The process of changing from a single vortex to multiple vortices is called **tornado breakdown**.

A ratio called the **swirl ratio** can be used to anticipate tornado breakdown and the multi-vortex nature of a parent tornado:

$$S = M_{tan} / W \quad \bullet(15.61)$$

where W is the average updraft speed in a mesocyclone, and M_{tan} is the tangential wind component around the mesocyclone. If we idealize the mesocyclone as being cylindrical, then:

$$S = \frac{R_{MC} \cdot M_{tan}}{2z_i \cdot M_{rad}} \quad \bullet(15.62)$$

where M_{rad} is the inflow speed (i.e., radial velocity component,) R_{MC} is the radius of the mesocyclone,

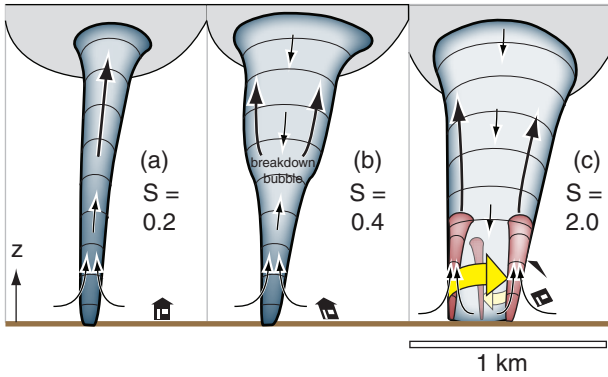

Figure 15.52
 Sketch of the evolution of a tornado (blue shading) and how the bottom can separate into multiple vortices (red shading) as the swirl ratio (S) increases. The multiple suction vortices move around the perimeter (yellow arrow) of the parent tornado

and z_i is the depth of the atmospheric boundary-layer. For the special case of $R_{MC} \approx 2z_i$, then:

$$S \approx M_{tan} / M_{rad} \quad \bullet(15.63)$$

When the swirl ratio is small (0.1 to 0.3), tornadoes have a single, well-defined, smooth-walled funnel (Fig. 15.52a), based on laboratory simulations. There is low pressure at the center of the tornado (**tornado core**), and the core contains updrafts at all heights. Core radius R_o of the tornado is typically 5% to 25% of the updraft radius, R_{MC} , in the mesocyclone.

If conditions change in the mesocyclone to have faster rotation and slower updraft, then the swirl ratio increases. This is accompanied by a turbulent downdraft in the top of the tornado core (Fig. 15.52b). The location where the core updraft and downdraft meet is called the **breakdown bubble**, and this stagnation point moves downward as the swirl ratio increases. The tornado is often wider above the stagnation point.

As the swirl ratio increases to a value of $S^* \approx 0.45$ (**critical swirl ratio**), the breakdown bubble gradually moves downward to the ground. The core now has a turbulent downdraft at all altitudes down to the ground, while around the core are strong turbulent updrafts around the larger-diameter tornado. At swirl ratios greater than the critical value, the parent tornado becomes a large-diameter helix of rotating turbulent updraft air, with a downdraft throughout the whole core.

At swirl ratios of about $S \geq 0.8$, the parent tornado creates multiple daughter vortices around its perimeter (Fig 15.52c). As S continues to increase toward 3 and beyond, the number of multiple vortices increases from 2 up to 6.

Wind speeds and damage are greatest in these small suction vortices. The individual vortices not

Sample Application

At radius 2.5 km, a mesocyclone has a radial velocity of 1 m s^{-1} and a tangential velocity of 3 m s^{-1} . If the atmospheric boundary layer is 1.5 km thick, find the swirl ratio.

Find the Answer

Given: $M_{rad} = 1 \text{ m s}^{-1}$, $M_{tan} = 3 \text{ m s}^{-1}$,
 $R_{MC} = 2500 \text{ m}$, and $z_i = 1.5 \text{ km}$
 Find: $S = ?$ (dimensionless)

Although eq. (15.63) is easy to use, it contains some assumptions that might not hold for our situation. Instead, use eq. (15.62):

$$S = \frac{(2500 \text{ m}) \cdot (3 \text{ m/s})}{2 \cdot (1500 \text{ m}) \cdot (1 \text{ m/s})} = \underline{2.5} \text{ (dimensionless)}$$

Check: Physics and units OK.

Exposition: Because this swirl ratio exceeds the critical value, multiple vortices are likely.

Often W is not known and hard to measure. But using mass continuity, the vertical velocity in eq. (15.61) can be estimated from the radial velocity for eq. (15.62), which can be easier to estimate.

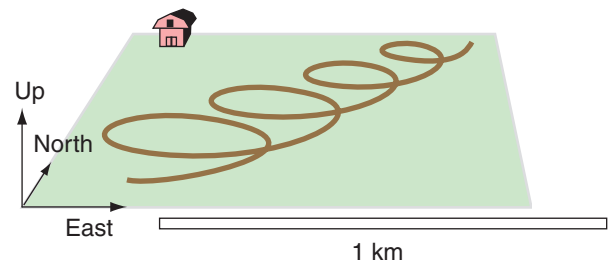

Figure 15.53
 Cycloidal damage path in a farm field caused by a tornadic suction vortex embedded in a larger diameter parent tornado.

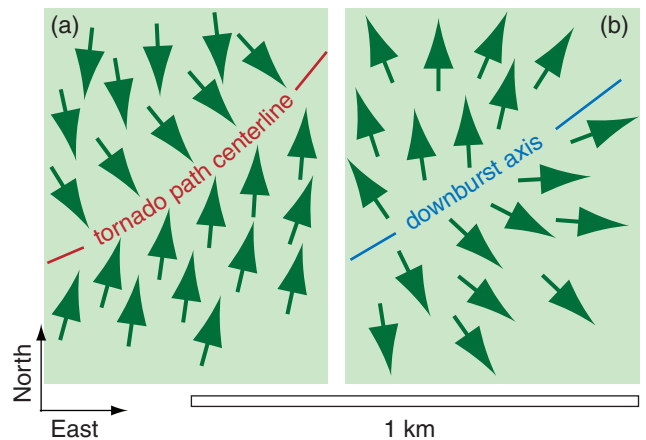

Figure 15.54
 Damage signatures of (a) tornadoes and (b) downbursts in a forest, as seen in aerial photographs of tree blowdown. Green arrows represent blown-down trees.

only circulate around the perimeter of the parent tornado, but the whole tornado system translates over the ground as the thunderstorm moves across the land. Thus, each vortex traces a cycloidal pattern on the ground, which is evident in post-tornado aerial photographs as cycloidal damage paths to crops (Fig. 15.53).

When single-vortex tornadoes move over a forest, they blow down the trees in a unique pattern that differs from tree blowdown patterns caused by straight-line downburst winds (Fig. 15.54). Sometimes these patterns are apparent only from an aerial vantage point.

15.5. REVIEW

Supercell thunderstorms can create tornadic winds, straight-line winds, downbursts, lightning, heavy rain, hail, and vigorous turbulence.

Larger hail is possible in storms with stronger updraft velocities, which is related to CAPE. When precipitation falls into drier air, both precipitation drag and evaporative cooling can cause acceleration of downdraft winds. When the downburst wind hits the ground, it spreads out into straight-line winds, the leading edge of which is called a gust front. Dust storms (haboobs) and arc clouds are sometimes created by gust fronts.

As ice crystals and graupel particles collide within thunderstorm updrafts they each transfer a small amount of charge. Summed over billions of such collisions in a thunderstorm, sufficient voltage gradient builds up to create lightning. The heat from lightning expands air to create the shock and sound waves we call thunder. Horizontal wind shear can be tilted into the vertical to create mesocyclones and tornadoes.

15.6. HOMEWORK EXERCISES

15.6.1. Broaden Knowledge & Comprehension

B1. Search the web for (and print the best examples of) photographs of:

- a. tornadoes
 - (i) supercell tornadoes
 - (ii) landspouts
 - (iii) waterspouts
 - (iv) gustnadoes
- b. gust fronts and arc clouds
- c. hailstones, and hail storms
- d. lightning

- (i) CG
- (ii) IC (including spider lightning, also known as lightning crawlers)
- (iii) a bolt from the blue

e. damage caused by intense tornadoes
(Hint: search on “storm stock images photographs”.)

Discuss the features of your resulting photos with respect to information you learned in this chapter.

B2. Search the web for (and print the best examples of) radar reflectivity images of

- a. hook echoes
- b. gust fronts
- c. tornadoes

Discuss the features of your resulting image(s) with respect to information you learned in this chapter.

B3. Search the web for (and print the best example of) real-time maps of lightning locations, as found from a lightning detection network or from satellite. Print a sequence of 3 images at about 30 minute intervals, and discuss how you can diagnose thunderstorm movement and evolution from the change in the location of lightning-strike clusters.

B4. Search the web for discussion of the health effects of being struck by lightning, and write or print a concise summary. Include information about how to resuscitate people who were struck.

B5. Search the web for, and summarize or print, recommendations for safety with respect to:

- a. lightning
- b. tornadoes
- c. straight-line winds and derechos
- d. hail
- e. flash floods
- f. thunderstorms (in general)

B6. Search the web (and print the best examples of) maps that show the frequency of occurrence of:

- a. tornadoes & tornado deaths
- b. lightning strike frequency & lightning deaths
- c. hail
- d. derechos

B7. Search the web for, and print the best example of, a photographic guide on how to determine Fujita or Enhanced Fujita tornado intensity from damage surveys.

B8. Search the web for (and print the best examples of) information about how different building or construction methods respond to tornadoes of different intensities.

B9. Search the web for, and print and discuss five tips for successful and safe tornado chasing.

B10. Use the internet to find sites for tornado chasers. The National Severe Storms Lab (NSSL) web site might have related info.

B11. During any 1 year, what is the probability that a tornado will hit any particular house? Try to find the answer on the internet.

B12. Search the web for private companies that provide storm-chasing tours/adventures/safaris for paying clients. List 5 or more, including their web addresses, physical location, and what they specialize in.

B13. Blue jets, red sprites, and elves are electrical discharges that can be seen as very brief glows in the mesosphere. They are often found at 30 to 90 km altitude over thunderstorms. Summarize and print info from the internet about these discharges, and included some images.

B14. Search the web for, and print one best example of, tornadoes associated with hurricanes.

B15. Search the web for a complete list of tornado outbreaks and/or tornado outbreak sequences. Print 5 additional outbreaks that were large and/or important, but which weren't already included in this chapter in the list of outbreaks. Focus on more-recent outbreaks.

B16. With regard to tornadoes, search the web for info to help you discuss the relative safety or dangers of:

- a. being in a storm shelter
- b. being in an above-ground tornado safe room
- c. being in a mobile home or trailer
- d. hiding under bridges and overpasses
- e. standing above ground near tornadoes

B17. Search the web for examples of downburst, gust front, or wind-shear sensors and warning systems at airports, and summarize and print your findings.

B18. Search the web for maps of **tornado alley**; namely, locations with frequent tornadoes.

15.6.2. Apply

A1. If a thunderstorm cell rains for 0.5 h at the precipitation rate (mm h^{-1}) below, calculate both the net latent heat released into the atmosphere, and the average warming rate within the troposphere.

- a. 50 b. 75 c. 100 d. 125 e. 150
- f. 175 g. 200 h. 225 i. 250 j. 275
- k. 300 l. 325 m. 350 n. 375 o. 400

A2. Indicate the TORRO hail size code, and descriptive name, for hail of diameter (cm):

- a. 0.6 b. 0.9 c. 1.2 d. 1.5 e. 1.7
- f. 2.1 g. 2.7 h. 3.2 i. 3.7 j. 4.5
- k. 5.5 l. 6.5 m. 7.5 n. 8.0 o. 9.5

A3. Graphically estimate the terminal fall velocity of hail of diameter (cm):

- a. 0.6 b. 0.9 c. 1.2 d. 1.5 e. 1.7
- f. 2.1 g. 2.7 h. 3.2 i. 3.7 j. 4.5
- k. 5.5 l. 6.5 m. 7.5 n. 8.0 o. 9.5

A4. A supercooled cloud droplet of radius $40 \mu\text{m}$ hits a large hailstone. Using the temperature ($^{\circ}\text{C}$) of the droplet given below, is the drop cold enough to freeze instantly (i.e., is its temperature deficit sufficient to compensate the latent heat of fusion released)? Based on your calculations, state whether the freezing of this droplet would contribute to a layer of clear or white (porous) ice on the hailstone.

- a. -40 b. -37 c. -35 d. -32 e. -30
- f. -27 g. -25 h. -22 i. -20 j. -17
- k. -15 l. -13 m. -10 n. -7 o. -5

A5. Given the sounding in exercise A3 of the previous chapter, calculate the portion of SB CAPE between altitudes where the environmental temperature is -10 and -30°C . Also, indicate if rapid hail growth is likely.

A6. Given the table below of environmental conditions, calculate the value of Significant Hail Parameter (SHIP), and state whether this environment favors the formation of hailstone $> 5 \text{ cm}$ diameter (assuming a thunderstorm indeed forms).

Exercise	a	b	c	d
MUCAPE (J kg^{-1})	2000	2500	3000	3500
r_{MUP} (g kg^{-1})	10	12	14	16
$\gamma_{70-50kPa}$ ($^{\circ}\text{C km}^{-1}$)	2	4	6	8
T_{50kPa} ($^{\circ}\text{C}$)	-20	-15	-10	-5
TSM_{0-6km} (m s^{-1})	20	30	40	50

A7. For the downburst acceleration equation, assume that the environmental air has temperature 2°C and mixing ratio 3 g kg^{-1} at pressure 85 kPa . A cloudy air parcel at that same height has the same temperature, and is saturated with water vapor and carries liquid water at the mixing ratio (g kg^{-1}) listed below. Assume no ice crystals.

- (1) Find portion of vertical acceleration due to the combination of temperature and water vapor effects.
- (2) Find the portion of vertical acceleration due to the liquid water loading only.

(3) By what amount would the virtual potential temperature of an air parcel change if all the liquid water evaporates and cools the air?

(4) If all of the liquid water were to evaporate and cool the air parcel, find the new vertical acceleration.

The liquid water mixing ratios (g kg^{-1}) are:

- a. 20 b. 18 c. 16 d. 14 e. 12 f. 10 g. 9
h. 8 i. 7 j. 6 k. 5 l. 4 m. 3 n. 2

A8. Given the sounding from exercise A3 of the previous chapter, assume a descending air parcel in a downburst follows a moist adiabat all the way down to the ground. If the descending parcel starts at the pressure (kPa) indicated below, and assuming its initial temperature is the same as the environment there, plot both the sounding and the descending parcel on a thermo diagram, and calculate the value of downdraft CAPE.

- a. 80 b. 79 c. 78 d. 77 e. 76 f. 75 g. 74
h. 73 i. 72 j. 71 k. 70 l. 69 m. 68 n. 67

A9. Find the downdraft speed if the DCAPE (J kg^{-1}) for a downburst air parcel is:

- a. -200 b. -400 c. -600 d. -800 e. -1000
f. -1200 g. -1400 h. -1600 i. -1800 j. -2000
k. -2200 l. -2400 m. -2600 n. -2800 o. -3000

A10. If a downburst has the same potential temperature as the environment, and starts with vertical velocity (m s^{-1} , negative for descending air) given below, use Bernoulli's equation to estimate the maximum pressure perturbation at the ground under the downburst.

- a. -2 b. -4 c. -6 d. -8 e. -10
f. -12 g. -14 h. -16 i. -18 j. -20
k. -22 l. -24 m. -26 n. -28 o. -30

A11. Same as the previous exercise, but in addition to the initial downdraft velocity, the descending air parcel is colder than the environment by the following product of virtual potential temperature depression and initial altitude ($^{\circ}\text{C}\cdot\text{km}$):

- (1) -0.5 (2) -1 (3) -1.5 (4) -2
(5) -2.5 (6) -3 (7) -3.5 (8) -4
(9) -4.5 (10) -5 (11) -5.5 (12) -6
(13) -6.5 (14) -7 (15) -7.5 (16) -8

A12. Find the acceleration (m s^{-2}) of outflow winds from under a downburst, assuming a maximum mesohigh pressure (kPa) perturbation at the surface as given below, and a radius of the mesohigh of 3 km.

- a. 0.1 b. 0.2 c. 0.3 d. 0.4 e. 0.5
f. 0.6 g. 0.7 h. 0.8 i. 0.9 j. 1.0
k. 1.1 l. 1.2 m. 1.3 n. 1.4 o. 1.5

A13. How fast will a gust front advance, and what will be its depth, at distance 6 km from the center of a downburst. Assume the downburst has radius 0.5 km and speed 9 m s^{-1} , and that the environmental around the downburst is 28°C . The magnitude of the temperature deficit ($^{\circ}\text{C}$) is:

- a. 1 b. 1.5 c. 2 d. 2.5 e. 3 f. 3.5
g. 4 h. 4.5 i. 5 j. 5.5 k. 6 l. 6.5
m. 7 n. 7.5 o. 8 p. 8.5 q. 9 r. 9.5

A14(S). Draw a graph of gust front depth and advancement speed vs. distance from the downburst center, using data from the previous exercise.

A15. Given a lightning discharge current (kA) below and a voltage difference between the beginning to end of the lightning channel of 10^{10} V , find (1) the resistance of the ionized lightning channel and (2) the amount of charge (C) transferred between the cloud and the ground during the $20 \mu\text{s}$ lifetime of the lightning stroke.

- a. 2 b. 4 c. 6 d. 8 e. 10 f. 15 g. 20
h. 40 i. 60 j. 80 k. 100 l. 150 m. 200 n. 400

A16. To create lightning in (1) dry air, and (2) cloudy air, what voltage difference is required, given a lightning stroke length (km) of:

- a. 0.2 b. 0.4 c. 0.6 d. 0.8 e. 1 f. 1.2 g. 1.4
h. 1.6 i. 1.8 j. 2.0 k. 2.5 l. 3 m. 4 n. 5

A17. For an electrical potential across the atmosphere of $1.3 \times 10^5 \text{ V km}^{-1}$, find the current density if the resistivity ($\Omega\cdot\text{m}$) is:

- a. 5×10^{13} b. 1×10^{13} c. 5×10^{12} d. 1×10^{12} e. 5×10^{11}
f. 1×10^{11} g. 5×10^{10} h. 1×10^{10} i. 5×10^9 j. 1×10^9
k. 5×10^8 l. 1×10^8 m. 5×10^7 n. 1×10^7 o. 5×10^6

A18. What is the value of peak current in a lightning stroke, as estimated using a lightning detection network, given the following measurements of electrical field E and distance D from the ground station.

- | | $-E$ (V m^{-1}) | D (km) |
|----|----------------------------|----------|
| a. | 1 | 10 |
| b. | 1 | 50 |
| c. | 2 | 10 |
| d. | 2 | 100 |
| e. | 3 | 20 |
| f. | 3 | 80 |
| g. | 4 | 50 |
| h. | 4 | 100 |
| i. | 5 | 50 |
| j. | 5 | 200 |
| k. | 6 | 75 |
| l. | 6 | 300 |

A19. For a power line struck by lightning, what is the probability that the lightning-generated current (kA) is greater than:

- a. 2 b. 4 c. 6 d. 8 e. 10 f. 15 g. 20
h. 40 i. 60 j. 80 k. 100 l. 150 m. 200 n. 400

A20. When lightning strikes an electrical power line it causes a surge that rapidly reaches its peak but then slowly decreases. How many seconds after the lightning strike will the surge have diminished to the fraction of the peak surge given here:

- a. 0.1 b. 0.15 c. 0.2 d. 0.25 e. 0.3
f. 0.35 g. 0.4 h. 0.45 i. 0.5 j. 0.55
k. 0.6 l. 0.65 m. 0.7 n. 0.75 o. 0.8

A21(S). If lightning heats the air to the temperature (K) given below, then plot (on a log-log graph) the speed (Mach number), pressure (as ratio relative to background pressure), and radius of the shock front vs. time given ambient background pressure of 100 kPa and temperature 20°C.

- a. 16,000 b. 17,000 c. 18,000 d. 19,000
e. 20,000 f. 21,000 g. 22,000 h. 23,000
i. 24,000 j. 25,000 k. 26,000 l. 27,000
m. 28,000 n. 29,000 o. 30,000

A22. What is the speed of sound in calm air of temperature (°C):

- a. -20 b. -18 c. -16 d. -14 e. -12
f. -10 g. -8 h. -6 i. -4 j. -2
k. 0 l. 2 m. 4 n. 6 o. 8
p. 10 q. 12 r. 14 s. 16 t. 18

A23(S). Create a graph with three curves for the time interval between the “flash” of lightning and the “bang” of thunder vs. distance from the lightning. One curve should be zero wind, and the other two are for tail and head winds of magnitude (m s^{-1}) given below. Given $T_{\text{environment}} = 295 \text{ K}$.

- a. 2 b. 4 c. 6 d. 8 e. 10 f. 12 g. 14
h. 16 i. 18 j. 20 k. 22 l. 24 m. 26 n. 28

A24(S). For a lightning stroke 2 km above ground in a calm adiabatic environment of average temperature 300 K, plot the thunder ray paths leaving downward from the lightning stroke, given that they arrive at the ground at the following elevation angle (°).

- a. 5 b. 6 c. 7 d. 8 e. 9 f. 10 g. 11
h. 12 i. 13 j. 14 k. 15 l. 16 m. 17 n. 18
o. 19 p. 20 q. 21 r. 22 s. 23 t. 24 u. 25

A25. What is the minimum inaudibility distance for hearing thunder from a sound source 7 km high in an environment of $T = 20^\circ\text{C}$ with no wind. Given a lapse rate ($^\circ\text{C km}^{-1}$) of:

- a. 9.8 b. 9 c. 8.5 d. 8 e. 7.5 f. 7 g. 6.5
h. 6 i. 5.5 j. 5 k. 4.5 l. 4 m. 3.5 n. 3
o. 2.5 p. 2 q. 1.5 r. 1 s. 0.5 t. 0 u. -1

A26. How low below ambient 100 kPa pressure must the core pressure of a tornado be, in order to support max tangential winds (m s^{-1}) of:

- a. 20 b. 30 c. 40 d. 50 e. 60 f. 70 g. 80
h. 90 i. 100 j. 110 k. 120 l. 130 m. 140 n. 150

A27(S). For a Rankine Combined Vortex model of a tornado, plot the pressure (kPa) and tangential wind speed (m s^{-1}) vs. radial distance (m) out to 125 m, for a tornado of core radius 25 m and core pressure deficit (kPa) of:

- a. 0.1 b. 0.2 c. 0.3 d. 0.4 e. 0.5
f. 0.6 g. 0.7 h. 0.8 i. 0.9 j. 1.0
k. 1.1 l. 1.2 m. 1.3 n. 1.4 o. 1.5

A28. If the max tangential wind speed in a tornado is 100 m s^{-1} , and the tornado translates at the speed (m s^{-1}) given below, then what is the max wind speed (m s^{-1}), and where is it relative to the center of the tornado and its track?

- a. 2 b. 4 c. 6 d. 8 e. 10 f. 12 g. 14
h. 16 i. 18 j. 20 k. 22 l. 24 m. 26 n. 28

A29. What are the Enhanced Fujita and TORRO intensity indices for a tornado of max wind speed (m s^{-1}) of

- a. 20 b. 30 c. 40 d. 50 e. 60 f. 70 g. 80
h. 90 i. 100 j. 110 k. 120 l. 130 m. 140 n. 150

A30 Find the pressure (kPa) at the edge of the tornado condensation funnel, given an ambient near-surface pressure and temperature of 100 kPa and 35°C , and a dew point ($^\circ\text{C}$) of:

- a. 30 b. 29 c. 28 d. 27 e. 26 f. 25 g. 24
h. 23 i. 22 j. 21 k. 20 l. 19 m. 18 n. 17

A31. For the winds of exercise A18 (a, b, c, or d) in the previous chapter, first find the storm movement for a

- (1) normal supercell
- (2) right-moving supercell
- (3) left-moving supercell

Then graphically find and plot on a hodograph the storm-relative wind vectors.

A32. Same as previous exercise, except determine the (U_s, V_s) components of storm motion, and then list the (U_j', V_j') components of storm-relative winds.

A33. A mesocyclone at 38°N is in an environment where the vertical stretching ($\Delta W/\Delta z$) is (20 m s^{-1}) / (2 km). Find the rate of vorticity spin-up due to

stretching only, given an initial relative vorticity (s^{-1}) of

- a. 0.0002 b. 0.0004 c. 0.0006 d. 0.0008 e. 0.0010
 f. 0.0012 g. 0.0014 h. 0.0016 i. 0.0018 j. 0.0020
 k. 0.0022 l. 0.0024 m. 0.0026 n. 0.0028 o. 0.0030

A34. Given the hodograph of storm-relative winds in Fig. 15.40b. Assume that vertical velocity increases with height according to $W = a \cdot z$, where $a = (5 \text{ m s}^{-1})/\text{km}$. Considering only the tilting terms, find the vorticity spin-up based on the wind-vectors for the following pairs of heights (km):

- a. 0,1 b. 1,2 c. 2,3 d. 3,4 e. 4,5 f. 5,6 g. 0,2
 h. 1,3 i. 2,4 j. 3,5 k. 4,6 l. 1,4 m. 2,5 n. 3,6
 o. 1,5 p. 2,6 q. 1,6

A35. Same as the previous exercise but for the storm-relative winds in the hodograph of the Sample Application in the “Storm-relative Winds” subsection of the tornado section.

A36. Given the hodograph of winds in Fig. 15.40a. Assume $W = 0$ everywhere. Calculate the helicity H based on the wind-vectors for the following pairs of heights (km):

- a. 0,1 b. 1,2 c. 2,3 d. 3,4 e. 4,5 f. 5,6 g. 0,2
 h. 1,3 i. 2,4 j. 3,5 k. 4,6 l. 1,4 m. 2,5 n. 3,6
 o. 1,5 p. 2,6 q. 1,6

A37. Same as the previous exercise, but use the storm-relative winds from Fig. 15.40b to get the storm-relative helicity H' . (Hint, don't sum over all heights for this exercise.)

A38. Given the hodograph of winds in Fig. 15.40a. Assume that vertical velocity increases with height according to $W = a \cdot z$, where $a = (5 \text{ m s}^{-1})/\text{km}$. Calculate the vertical contribution to helicity (eq. 15.54) based on the wind-vectors for the following pairs of heights (km):

- a. 0,1 b. 1,2 c. 2,3 d. 3,4 e. 4,5 f. 5,6 g. 0,2
 h. 1,3 i. 2,4 j. 3,5 k. 4,6 l. 1,4 m. 2,5 n. 3,6
 o. 1,5 p. 2,6 q. 1,6

A39. Use the storm-relative winds in the hodograph of the Sample Application in the “Storm-relative Winds” subsection of the tornado section. Calculate the total storm-relative helicity (SRH) graphically for the following height ranges (km):

- a. 0,1 b. 0,2 c. 0,3 d. 0,4 e. 0,5 f. 0,6 g. 1,2
 h. 1,3 i. 1,4 j. 1,5 k. 1,6 l. 2,3 m. 2,4 n. 2,5
 o. 2,6 p. 3,5 q. 3,6

A40. Same as the previous exercise, but find the answer using the equations (i.e., NOT graphically).

A41. Estimate the intensity of the supercell and tornado (if any), given a 0-1 km storm-relative helicity ($\text{m}^2 \text{s}^{-2}$) of:

- a. 20 b. 40 c. 60 d. 80 e. 100 f. 120 g. 140
 h. 160 i. 180 j. 200 k. 220 l. 240 m. 260 n. 280
 o. 300 p. 320 q. 340 r. 360 s. 380 t. 400

A42. Given a storm-relative helicity of 220, find the energy-helicity index if the CAPE (J kg^{-1}) is:

- a. 200 b. 400 c. 600 d. 800 e. 1000 f. 1200
 g. 1400 h. 1600 i. 1800 j. 2000 k. 2200
 l. 2400 m. 2600 n. 2800 o. 3000

A43. Estimate the likely supercell intensity and tornado intensity (if any), given an energy-helicity index value of:

- a. 0.2 b. 0.4 c. 0.6 d. 0.8 e. 1.0 f. 1.2 g. 1.4
 h. 1.6 i. 1.8 j. 2.0 k. 2.2 l. 2.4 m. 2.6 n. 2.8
 o. 3.0 p. 3.2 q. 3.4 r. 3.6 s. 3.8 t. 4.0

A44. If the tangential winds around a mesocyclone updraft are 20 m s^{-1} , find the swirl ratio of the average updraft velocity (m s^{-1}) is:

- a. 2 b. 4 c. 6 d. 8 e. 10 f. 12 g. 14
 h. 16 i. 18 j. 20 k. 22 l. 24 m. 26 n. 28
 o. 30 p. 32 q. 34 r. 36 s. 38 t. 40

A45. Given a mesocyclone with a tangential velocity of 20 m s^{-1} around the updraft region of radius 1000 m in a boundary layer 1 km thick. Find the swirl ratio and discuss tornado characteristics, given a radial velocity (m s^{-1}) of:

- a. 1 b. 2 c. 3 d. 4 e. 5 f. 6 g. 7
 h. 8 i. 9 j. 10 k. 11 l. 12 m. 13 n. 14
 o. 15 p. 16 q. 17 r. 18 s. 19 t. 20

15.6.3. Evaluate & Analyze

E1. Why cannot hook echoes be used reliably to indicate the presence of a tornado?

E2. Cases of exceptionally heavy rain were discussed in the “Precipitation and Hail” section of this chapter and in the Precipitation chapter section on Rainfall Rates. However, most of those large rainfall rates occurred over exceptionally short durations (usually much less than an hour). Explain why longer-duration extreme-rainfall rates are unlikely.

E3. Use the info in Fig. 15.4 and the relationship between max likely updraft speed and CAPE, to plot a new graph of max possible hailstone diameter vs. total CAPE.

E4. In Fig. 15.7, what is the advantage to ignoring a portion of CAPE when estimating the likelihood of large hail? Explain.

E5. Explain why the various factors in the SHIP equation (15.4) are useful for predicting hail?

E6. Figures 15.5 and 15.10 show top and end views of the same thunderstorm, as might be seen with weather radar. Draw a side view (as viewed from the southeast by a weather radar) of the same thunderstorm. These 3 views give a blueprint (mechanical drawing) of a supercell.

E7. Cloud seeding (to change hail or rainfall) is a difficult social and legal issue. The reason is that even if you did reduce hail over your location by cloud seeding, an associated outcome might be increased hail or reduced rainfall further downwind. So solving one problem might create other problems. Discuss this issue in light of what you know about sensitive dependence of the atmosphere to initial conditions (the “butterfly effect”), and about the factors that link together the weather in different locations.

E8. a. Confirm that each term in eq. (15.5) has the same units.

b. Discuss how terms A and C differ, and what they each mean physically.

c. In term A, why is the numerator a function of $\Delta P'$ rather than ΔP ?

E9. a. If there were no drag of rain drops against air, could there still be downbursts of air?

b. What is the maximum vertical velocity of large falling rain drops relative to the ground, knowing that air can be dragged along with the drops as a downburst? (Hint: air drag depends on the velocity of the drops relative to the air, not relative to the ground.)

c. Will that maximum fall velocity relative to the ground be reached at the ground, or at some height well above ground? Why?

E10. A raindrop falling through unsaturated air will cool to a certain temperature because some of the drop evaporates. State the name of this temperature.

E11. Suppose that an altocumulus (mid-tropospheric) cloud exists within an environment having a linear, conditionally unstable, temperature profile with height. Rain-laden air descends from this little cloud, warming at the moist adiabatic rate as it descends. Because this warming rate is less than the conditionally unstable lapse rate of the environment, the temperature perturbation of the air relative to the environment becomes colder as it descends.

But at some point, all the rain has evaporated. Descent below this altitude continues because the air parcel is still colder than the environment. However, during this portion of descent, the air parcel warms dry adiabatically, and eventually reaches an altitude where its temperature equals that of the environment. At this point, its descent stops. Thus, there is a region of strong downburst that does NOT reach the ground. Namely, it can be a hazard to aircraft even if it is not detected by surface-based wind-shear sensors.

Draw this process on a thermo diagram, and show how the depth of the downburst depends on the amount of liquid water available to evaporate.

E12. Demonstrate that eq. (15.10) equates kinetic energy with potential energy. Also, what assumptions are implicit in this relationship?

E13. Eqs. (15.12) and (15.13) show how vertical velocities (w_d) are tied to horizontal velocities (M) via pressure perturbations P' . Such coupling is generically called a circulation, and is the dynamic process that helps to maintain the continuity of air (namely, the uniform distribution of air molecules in space). Discuss how horizontal outflow winds are related to DCAPE.

E14. Draw a graph of gust-front advancement speed and thickness vs. range R from the downburst center. Do what-if experiments regarding how those curves change with

a. outflow air virtual temperature?

b. downburst speed?

E15. Fig. 15.21 shows large accumulations of electrical charge in thunderstorm clouds. Why don't the positive and negative charge areas continually discharge against each other to prevent significant charge accumulation, instead of building up such large accumulations as can cause lightning?

E16. At the end of the INFO box about “Electricity in a Channel” is given an estimate of the energy dissipated by a lightning stroke. Compare this energy to:

a. The total latent heat available to the thunderstorm, given a typical inflow of moisture.

b. The total latent heat actually liberated based on the amount of rain falling out of a storm.

c. The kinetic energy associated with updrafts and downbursts and straight-line winds.

d. The CAPE.

E17. Look at both INFO boxes on electricity. Relate:

a. voltage to electrical field strength

- b. resistance to resistivity
- c. current to current density
- d. power to current density & electrical potential.

E18. If the electrical charging process in thunderstorms depends on the presence of ice, then why is lightning most frequently observed in the tropics?

- E19. a. Lightning of exactly 12 kA occurs with what probability?
- b. Lightning current in the range of 8 to 12 kA occurs with what probability?

E20. How does the shape of the lightning surge curve change with changes of parameters τ_1 and τ_2 ?

E21. Show why eqs. (15.22) and (15.32) are equivalent ways to express the speed of sound, assuming no wind.

E22. Do you suspect that nuclear explosions behave more like chemical explosions or like lightning, regarding the resulting shock waves, pressure, and density? Why?

E23. The equations for shock wave propagation from lightning assumed an isopycnal processes. Critique this assumption.

E24. In Earth's atmosphere, describe the conditions needed for the speed of sound to be zero relative to a coordinate system fixed to the ground. How likely are these conditions?

E25. What might control the max distance from lightning that you could hear thunder, if refraction was not an issue?

E26. Show how the expression of Snell's law in an environment with gradually changing temperature (eq. 15.36) is equivalent to, or reduces to, Snell's law across an interface (eq. 15.35).

E27. Show that eq. (15.39) for Snell's Law reduces to eq. (15.34) in the limit of zero wind.

E28. Use Bernoulli's equation from the Regional Winds chapter to derive the relationship between tornadic core pressure deficit and tangential wind speed. State all of your assumptions. What are the limitations of the result?

E29(S). Suppose that the actual tangential velocity in a tornado is described by a **Rankine combined vortex (RCV)**. Doppler radars, however, cannot

measure radial velocities at any point, but instead observe velocities averaged across the radar beam width. So the Doppler radar sees a smoothed version of the Rankine combined vortex. It is this smoothed tangential velocity shape that is called a **tornado vortex signature (TVS)**, and for which the Doppler-radar computers are programmed to recognize. This exercise is to create the tangential velocity curve similar to Fig. 15.34, but for a TVS.

Let ΔD be the diameter of radar beam at some range from the radar, and R_o be the core radius of tornado. The actual values of ΔD and R_o are not important: instead consider the dimensionless ratio $\Delta D/R_o$. Compute the TVS velocity at any distance R from the center of the tornado as the average of all the RCV velocities between radii of $[(R/R_o) - (\Delta D/2R_o)]$ and $[(R/R_o) + (\Delta D/2R_o)]$, and repeat this calculation for many values of R/R_o to get a curve. This process is called a **running average**. Create this curve for $\Delta D/R_o$ of:

- a. 1.0 b. 1.5 c. 2.0 d. 2.5 e. 3.0 f. 3.5 g. 4.0
- h. 4.5 i. 5.0 j. 0.9 k. 0.8 l. 0.7 m. 0.6 n. 0.5

Hint: Either do this by analytically integrating the RCV across the radar beam width, or by brute-force averaging of RCV values computed using a spreadsheet.

E30(S). For tornadoes, an alternative approximation for tangential velocities M_{tan} as a function of radius R is given by the **Burgers-Rott Vortex (BRV)** equation:

$$\frac{M_{tan}}{M_{tan\ max}} = 1.398 \left(\frac{R_o}{R} \right) \left[1 - e^{-(1.12 \cdot R/R_o)^2} \right] \quad (15.64)$$

where R_o is the core radius.

Plot this curve, and on the same graph re-plot the Rankine combined vortex (RCV) curve (similar to Fig. 15.33). Discuss what physical processes in the tornado might be included in the BRV that are not in the RCV, to explain the differences between the two curves.

E31. For the Rankine combined vortex (RCV), both the tangential wind speed and the pressure deficit are forced to match at the boundary between the tornado core and the outer region. Does the pressure gradient also match at that point? If not, discuss any limitations that you might suggest on the RCV.

E32. Suppose a suction vortex with max tangential speed $M_{s\ tan}$ is moving around a parent tornado of tangential speed $M_{p\ tan}$ and the parent tornado is translating at speed M_{tr} . Determine how the max speed varies with position along the resulting cycloidal damage path.

E33. The TORRO scale is related to the **Beaufort** wind scale (**B**) by:

$$B = 2 \cdot (T + 4) \quad (15.63)$$

The Beaufort scale is discussed in detail in the Hurricane chapter, and is used to classify ocean storms and sea state. Create a graph of Beaufort scale vs. TORRO scale. Why cannot the Beaufort scale be used to classify tornadoes?

E34. Volcanic eruptions can create blasts of gas that knock down trees (as at Mt. St. Helens, WA, USA). The **air burst** from astronomical meteors speeding through the atmosphere can also knock down trees (as in Tunguska, Siberia). Explain how you could use the TORRO scale to classify these winds.

E35. Suppose that tangential winds around a tornado involve a balance between pressure-gradient force, centrifugal force, and Coriolis force. Show that anticyclonically rotating tornadoes would have faster tangential velocity than cyclonic tornadoes, given the same pressure gradient. Also, for anticyclonic tornadoes, are there any tangential velocity ranges that are excluded from the solution of the equations (i.e., are not physically possible)? Assume N. Hem.

E36. Does the outside edge of a tornado condensation funnel have to coincide with the location of fastest winds? If not, then is it possible for the debris cloud (formed in the region of strongest winds) radius to differ from the condensation funnel radius? Discuss.

E37. Given a fixed temperature and dew point, eq. (15.48) gives us the pressure at the outside edge of the condensation funnel.

a. Is it physically possible (knowing the governing equations) for the pressure deficit at the tornado axis to be higher than the pressure deficit at the visible condensation funnel? Why?

b. If the environmental temperature and dew point don't change, can we infer that the central pressure deficit of a large-radius tornado is lower than that for a small-radius tornado? Why or why not?

E38. Gustnadoes and dust devils often look very similar, but are formed by completely different mechanisms. Compare and contrast the processes that create and enhance the vorticity in these vortices.

E39. From Fig. 15.40a, you see that the winds at 1 km above ground are coming from the southeast. Yet, if you were riding with the storm, the storm relative winds that you would feel at 1 km altitude would be from the northeast, as shown for the same data in Fig. 15.40b. Explain how this is possible; namely, explain how the storm has boundary layer inflow entering it from the northeast even though the actual wind direction is from the southeast.

E40. Consider Fig. 15.42.

a. What are the conceptual (theoretical) differences between streamwise vorticity, and the vorticity around a local-vertical axis as is usually studied in meteorology?

b. If it is the streamwise (horizontal axis) vorticity that is tilted to give vorticity about a vertical axis, why don't we see horizontal-axis tornadoes forming along with the usual vertical tornadoes in thunderstorms? Explain.

E41. Compare eq. (15.51) with the full vorticity-tendency equation from the Extratropical Cyclone chapter, and discuss the differences. Are there any terms in the full vorticity equation that you feel should not have been left out of eq. (15.51)? Justify your arguments.

E42. Show that eq. (15.57) is equivalent to eq. (15.56). (Hint: use the average-wind definition given immediately after eq. (15.55).)

E43. Show mathematically that the area swept out by the storm-relative winds on a hodograph (such as the shaded area in Fig. 15.44) is indeed exactly half the storm-relative helicity. (Hint: Create a simple hodograph with a small number of wind vectors in easy-to-use directions, for which you can easily calculate the shaded areas between wind vectors. Then use inductive reasoning and generalize your approach to arbitrary wind vectors.)

E44. What are the advantages and disadvantages of eSRH and EHI relative to SRH?

E45. Suppose the swirl ratio is 1 for a tornado of radius 300 m in a boundary layer 1 km deep. Find the radial velocity and core pressure deficit for each tornado intensity of the

a. Enhanced Fujita scale. b. TORRO scale.

E46. One physical interpretation of the denominator in the swirl ratio (eq. 15.60) is that it indicates the volume of inflow air (per crosswind distance) that reaches the tornado from outside. Provide a similar interpretation for the swirl-ratio numerator.

E47. The cycloidal damage sketched in Fig. 15.51 shows a pattern in between that of a true cycloid and a circle. Look up in another reference what the true cycloid shape is, and discuss what type of tornado behavior would cause damage paths of this shape.

15.6.4. Synthesize

S1. Since straight-line outflow winds exist surrounding downbursts that hit the surface, would you expect similar hazardous outflow winds where the updraft hits the tropopause? Justify your arguments.

S2. Suppose that precipitation loading in an air parcel caused the virtual temperature to increase, not decrease. How would thunderstorms differ, if at all?

S3. If hailstones were lighter than air, discuss how thunderstorms would differ, if at all.

S4. If all hailstones immediately split into two when they reach a diameter of 2 cm, describe how hail storms would differ, if at all.

S5. Are downbursts equally hazardous to both light-weight, small private aircraft and heavy fast commercial jets? Justify your arguments?

S6. Suppose that precipitation did not cause a downward drag on the air, and that evaporation of precipitation did not cool the air. Nonetheless, assume that thunderstorms have a heavy precipitation region. How would thunderstorms differ, if at all?

S7. Suppose that downbursts did not cause a pressure perturbation increase when they hit the ground. How would thunderstorm hazards differ, if at all?

S8. Suppose that downbursts sucked air out of thunderstorms. How would thunderstorms differ, if at all?

S9. Do you think that lightning could be productively utilized? If so, describe how.

S10. Suppose air was a much better conductor of electricity. How would thunderstorms differ, if at all?

S11. Suppose that once a lightning strike happened, the resulting plasma path that was created through air persists as a conducting path for 30 minutes. How would thunderstorms differ, if at all.

S12. Suppose that the intensity of shock waves from thunder did not diminish with increasing distance. How would thunderstorm hazards differ, if at all?

S13. Refraction of sound can make noisy objects sound quieter, and can amplify faint sounds by focusing them. For the latter case, consider what happens to sound waves traveling different paths as they all reach the same focus point. Describe what would happen there.

S14. The air outside of the core of a Rankine-combined-vortex (RCV) model of a tornado is moving around the tornado axis. Yet the flow is said to be **irrotational** in this region. Namely, at any point outside the core, the flow has no vorticity. Why is that? Hint: consider aspects of a flow that can contribute to relative vorticity (see the General Circulation chapter), and compare to characteristics of the RCV.

S15. What is the max tangential speed that a tornado could possibly have? What natural forces in the atmosphere could create such winds?

S16. Do anticyclonically rotating tornadoes have higher or lower core pressure than the surrounding environment? Explain the dynamics.

S17. Consider Fig. 15.36. If the horizontal pressure gradient near the bottom of tornadoes was weaker than that near the top, how would tornadoes be different, if at all?

S18. If a rapidly collapsing thunderstorm (nicknamed a **bursticane**, which creates violent downbursts and near-hurricane-force straight-line winds at the ground) has a rapidly sinking top, could it create a tornado above it due to stretching of the air above the collapsing thunderstorm? Justify your arguments.

S19. Positive helicity forms not only with updrafts and positive vorticity, but also with downdrafts and negative vorticity. Could the latter condition of positive helicity create mesocyclones and tornadoes? Explain.